



*Antologhia)*<sup>®</sup>



*Occasionali porosità o corrosioni o rugosità, che costituirebbero difetto e ragione di scarto nei comuni prodotti usciti da stampi meccanici proprio per essere identici, in oggetti di questa collezione - realizzati invece con tecniche antiche quali la fusione in terra e l'intervento della manualità - rappresentano una certificazione di autenticità e unicità. L'ossidazione nel tempo dell'ottone non verniciato forma una patina tipica degli oggetti che non hanno subito trattamenti, attestando la veridicità e l'artigianalità della collezione.*

*Occasional porosity, corrosions or wrinkles in this collection, that would usually be treated as defects and therefore waste in a normal production with mechanical moulds, gives it the proper taste of the antique manufacturing process, such as the heart sand casting and the handcrafts works, awarding it with a certificate of authenticity and originality. Natural brass oxidation along the years bring about a typical patina on the object surface, which haven't been treated, awarding the authenticity and the craftwork of the collection.*



15 *Accademia*

21 *Barocco*

27 *Bellagio*

33 *Busiri*

39 *Byblos*

45 *Capri*

51 *Firenze*

57 *Impero*

63 *Lidia*

69 *Louis XVI*

75 *Ottocento*

81 *Palatino*

87 *Roma*

93 *Settecento*

99 *Venezia*

105 *Nottolini*

*Toilet roses*

109 *Pomoli e pomolini per mobile*

*Door knobs and furniture knobs*

119 *Manigioni e battiporta*

*Pulls and door knockers*

139 *Maniglie incasso*

*Flush handles*

145 *Complementi*

*Complements*

*L'ossidazione nel tempo delle finiture non verniciate forma una patina tipica degli oggetti che non hanno subito trattamenti, attestando la veridicità e l'artigianalità della collezione.*

*Natural finishing oxidation along the years bring about a typical patina on the object surface, which haven't been treated, awarding the authenticity and the craftwork of the collection.*

*Antologhia)*<sup>®</sup>

sig. <sup>no</sup> *di* *pot* *com* *mo*

chevo già messa alla volta. f. alba mio. i stanti allora che  
sabato scorso giovedì (sua) *poter* *si* *on* *de* *di* *kasus* *vill*  
della Fratta *l'otto* *di* *soluto*: *ed* *meto* *di* *ui* *li* *bo* *vino* *lubi*  
in buona salute. *quali* *va* *a* *quolunquiam* *il* *loggion*.  
*io* *fin* *per* *ni* *vo* *meto* *molto* *meno* *al*  
*velo* *non* *lo* *ni* *pollo* *na* *con* *de* *ni* *com* *iso*



*ella* *vill* *della* *Frata*  
*di* *si* *non* *ge* *mo*  
*di* *si* *qu* *ovano* *di* *sa* *familiari*  
*Camel* *dell* *ff* *di* *ff*  
Avsiena *ella* *vill* *della* *Frata*  
*in* *val* *di* *Quana*



*Nascono da una selettiva ricerca tra i modelli del passato le nuove maniglie ora proposte dalla Colombo design. Si è puntato a ritrovare, nelle varie epoche dello stile, il valore esemplare e sempre attuale della bellezza.*

*La forma, come ha scritto un grande storico dell'arte, è precisa definizione della materia e dello spazio, "ma è anche suggestione, si estende e lievita nell'immaginario".*

*In queste nostre scelte la forma evoca e restituisce il senso di una lontana civiltà del vivere.*

*Da più di un secolo si tenta di contrastare l'impovertimento indotto dalla adozione di processi meccanizzati nella fattura degli oggetti d'uso quotidiano.*

*L'industrial design ha dato risposte a volte geniali a questa esigenza di qualità, ma sempre puntando su soluzioni coerenti con i moderni mezzi di produzione e a questi vincolate. Non ha avuto invece né la pretesa né la possibilità di rispondere alla domanda, più radicale e raffinata, di chi rimpiangeva il calore e il pregio non surrogabile che le cose avevano quando a dar loro corpo e linea era direttamente la mano dell'uomo. Anche sotto questo rispetto le maniglie della Colombo design si possono dire fascinoso macchine del tempo. Costituiscono infatti molto più che un semplice ritorno a remoti modelli: e non solo perché funzionalità, profili, volumi, materiali sono stati oggetto di un'attentissima rivisitazione progettuale.*

*A caratterizzarle e a qualificarle è pure il ricupero, nella loro fabbricazione, da un lato della manualità sino in fase di rifinitura e dall'altro di tecniche quali la fusione in terra.*

*Ne consegue, tra l'altro, un istruttivo capovolgimento nei criteri stessi di valutazione: occasionali porosità o tracce di corrosione o rugosità, che costituiscono difetto e fanno scarto nei comuni prodotti usciti da stampi meccanici proprio per essere identici, ridiventano - come sempre nei manufatti - preziose aggiunte: certificazioni di autenticità e unicità, magiche e visibili carezze del caso a un'opera dell'uomo.*

*The new handles proposed now by Colombo design emerged after careful search among selective models of the past.*

*They are aimed at rediscovering, in various eras of style, the exemplary and timeless value of beauty.*

*The shape, as a great art historian wrote, is a precise definition of matter and space, "but it is also fascination, it stretches and elevates the imagination."*

*In these choices of ours, shape evokes the sense of a distant civilization of living.*

*For over a century we have been trying to counter the impoverishment caused by the adoption of mechanized processes in the manufacturing of everyday objects.*

*Industrial design has at times given brilliant answers to this need for quality, but always focusing on solutions that are consistent with and bound to these modern means of production. But it had neither the pretensions nor the opportunity to answer the question, more radical and refined, of those who missed the warmth and irreplaceable value things had when it was man's hands that gave them body and line. Along these lines Colombo's handle can also be called fascinating time machines.*

*They constitute in fact much more than a simple return to ancient models.*

*Not only because functionalities, profiles, volumes, materials have undergone very careful planning study. To characterize them and qualify them is also the recovery, in their manufacture, on one side of the manual the dexterity during finishing and on the other the techniques like sand casting.*

*It follows, among other things, a reversal in educational evaluation criteria themselves: occasional signs of corrosion or porosity or wrinkles, that would usually be treated as defects and therefore waste in normal production with mechanical molds, become again - as always in products - valuable additions: certification of authenticity and uniqueness, and magical visibility caresses the case to a human work.*

	ITALIA ITALY	FRANCIA FRANCE
1400	Gotico internazionale International gothic Stile '400 italiano e inizi stile rinascimentale Italian Gothic style	Gotico internazionale fino al '500 circa International gothic until around 500 AC
1500	Pieno internazionale 1490-1550 High Renaissance 1490-1550 Tardo Rinascimento 1550-1600 Late Renaissance 1550-1600	Periodo di transizione Transition period Rinascimento 1550-1610 Renaissance 1550-1610
1600	Primo Seicento 1600-1645 Early seventeenth century 1600-1645 Seicento Barocco 1645-1675 Baroque styles of the seventeenth century 1645-1675	Luigi XIII 1610-1643 Louis XIII 1610-1643 Luigi XIV o Barocco 1643-1715 Louis XIV or Baroque 1643-1715
1700	Barocco Puro 1675-1740 Baroque 1675-1740 Barocchetto o Rococò 1740-1775 Rococo Style 1740-1775 Neo Classico 1775-1795 Neoclassicism 1775-1795	Reggenza e Rocaille 1715-1722 Regence and Rocaille 1715-1722 Luigi XV 1722-1774 Louis XV 1722-1774 Luigi XVI 1774-1792 Louis XVI 1774-1792
1800	Direttorio 1795-1805 Directoire 1795-1805 Impero 1805-1830 Empire 1805-1830 Primo Ottocento e Carlo Felice 1821-1838 Carlo Felice 1821-1838 Albertino 1831-1838 Albertino 1831-1838 Secondo Impero, Pieno Ottocento, Neo Gotico 1852-1870 Second Empire New Gothic style 1852-1870 Umbertino 1878-1900 Umbertian style 1878-1900	Direttorio 1792-1804 Directoire 1792-1804 Impero 1804-1815 Empire 1804-1815 Restaurazione 1815-1830 Restoration and Charles 1815-1830 Luigi Filippo 1830-1848 Louis Philippe 1830-1848 Secondo Impero 1852-1870 Second Empire 1852-1870
1900	Floreale Floral style	Art Nouveau Art Nouveau



Nr.	Silber	Messing
1	4-60	3-90
2	5-00	5-10
3	5-00	4-20
4	6-00	5-10
5	5-50	4-80
6	6-00	5-10
7	5-50	4-70
8	6-60	5-60
9	7-40	6-30
10	9-60	8-20

Schubriegelknöpfe u. Griffe, per Stück in K:

Nr.	Silber	Rot- brasse	Messing
1	0-60	0-50	0-40
2	0-70	0-60	0-50
3	0-80	0-70	0-60
4	0-90	0-80	0-70
5	0-50	0-42	0-30
6	0-70	0-60	0-50
7	1-30	1-08	0-92
8	1-60	1-40	1-20



Handröcker (Halb-  
per Stück in K:

Material	Rot- brunze	Mess- ing
0-80		
0-70	0-60	
0-80	0-70	0-60
0-80	0-70	0-60
0-90	0-70	0-66
0-96	0-84	0-70
0-10	0-96	0-72
0-80	0-70	0-66
0-90	0-76	0-66
0-80	0-70	0-60
0-90	0-76	0-66
0-00	0-84	0-76
0-00	0-84	0-76
0-70	0-60	0-50

Handröcker-  
Rosetten,  
per Stück in K:

Material	Rot- brunze	Mess- ing
0-12	0-10	0-08
0-14	0-12	0-10
0-26	0-22	0-18
0-36	0-30	0-24
0-60	0-42	0-36





*Idea antica e oggi potenziata da affinatissime tecnologie, la fusione è un intervento creativo sul metallo con il concorso essenziale di due elementi primordiali: terra e fuoco.*

*Al principio di tutto c'è lo stampo, fatto di un'umida sabbia argillosa, che accoglie per pressione l'impronta dei modelli originari che si vogliono riprodurre e la fissa in due parti, un sopra e un sotto, combacianti come le valve di una conchiglia. Aperto poi lo stampo e estratti i modelli, si predispongono un sistema di canali in cui il metallo fuso potrà scorrere nella sabbia e raggiungere le cave forme che vi sono state definite.*

*Ora è il momento più suggestivo e dalle immagini si capisce perché un tempo si vedesse nella metallurgia l'arte di un dio chiamato Vulcano. L'ottone, portato allo stato liquido in un forno ad alte temperature e prelevato con tazze di colata, viene versato nei canali dello stampo attraverso appositi pozzetti a imbuto. E' ancora incandescente.*

*Old idea, and now augmented by refined technologies, the merger is a creative intervention on the metal with the help of two essential primordial elements earth and fire.*

*At the beginning of everything there is the mold, made of damp clayey sand, that houses, by pressure, the footprint of the original models that are to be reproduced, and holds it in two parts, one above and one below, that fit together like the halves of a shell. Opened the mold and then extracted the models, a system of channels is set up in which the molten metal can flow into the sand and reach the hollow shapes that have been defined.*

*It is now the most striking moment and you will understand why once the art of metallurgy was seen in a god called Vulcan.*

*Brass, led to a liquid in a furnace at high temperatures and collected with cups of casting, the mold is poured into the channels through appropriate wells funnel. It's still hot.*







*Quando l'ottone dai circa mille gradi che aveva raggiunto nel forno torna alla normale temperatura e allo stato solido, si rompe lo stampo. Con una sega - è come il taglio del cordone ombelicale - si separano dai canali di fusione i pezzi ottenuti e si passa alla loro rifinitura.*

*When the brass, from about a thousand degrees in the oven, reaches back to normal temperature and the solid state, it breaks the mold. With a saw - it's like cutting the umbilical cord - are separated by channels of the pieces obtained by casting and go to their finishing.*





*Sapiente rifinitura a mano, per la quale ci si avvale di scalpelli, frese, lucidatrici. Fino all'ultimo, è la ricerca della qualità.*

*Skillful hand finishing then follows for which we make use of chisels, cutters, polishers. Until the end, it is the pursuit of quality.*





*Maniglie*  
*Handles*

Farbe die Schrift.  
 Da, wo man eine  
 den gewohnt war,  
 als einen grünen  
 3. soweit von einer  
 Rede sein konnte,  
 esen. Und trotz  
 ade durch diese  
 die Arbeit; sie  
 des jungen  
 näßig Wirt-  
 le Vorzüge  
 Mommene  
 er unver-  
 ung und  
 m ganz  
 Seine  
 s-bar.  
 Zu-  
 der  
 ist  
 ei

Ernst Neumann

**Wilh.: Busch = Ausstellung**  
**Künstler =**  
**haus**



**Bellevue =**  
**Str. 3**

Abb. 95. Lucian Bernhard: Ausstellungs-Plakat  
 ausgeführt von Hollerbaum & Schmidt in Berlin (zu Seite 91)

Sachplakate gar nicht über-  
 sehen, und für die Räch-  
 ternheit des Vorwurfs ent-  
 schädigt die Freude an der  
 geistvollen Mache und der  
 Farbenschönheit seiner Ar-  
 beiten. Zu dem Reizvoll-  
 stein, was er geschaffen hat,  
 sind auch seine reinen  
 Schrift- und Ornament-  
 plakate für die „National-  
 zeitung“, den „Hannover-  
 schen Anzeiger“, das Café  
 Scandinavia, die Ausstel-  
 lung 1913 des Deutschen  
 Künstlerbundes (Abb. 96)  
 u. a. zu rechnen. Figür-  
 liche Kompositionen gelin-  
 gen ihm dagegen meist  
 an Fülle der Ein-  
 bildung, an Phantasie, an  
 Tüchtigkeit der Ausführung,  
 an glänzender hervor-  
 tretender Saharet, die Färbung von ver-  
 schiedenen schon damals

weniger gut; er zeigt sich in ihnen zeichnerisch nicht immer der Phantasie, an glänzender hervor-  
 und vor allem fehlt es ihm an Beweglichkeit der Phantasie, an Tüchtigkeit der Ausführung, an glänzender hervor-  
 fälle. Sehr hübsch hat er in der Anzeige einer Wilhelm Busch-Ausstellung dessen  
 Fromme Helene ins Plakatmäßige überseht (Abb. 95).  
 Aus der Kunstanstalt von Hollerbaum & Schmidt ist auch eine glänzende  
 Affiche von Ernst Neumann für die berühmte Tänzerin Saharet hervor-  
 gegangen. Die Zeichnung war für die fabelhafte unter den schon damals  
 blühender Kühnheit — endlich einmal ein Schlager  
 Und was tat die Direktion des Win-  
 tergartens? Schon nach ganz kurzer  
 Zeit ersetzte sie Neumanns Arbeit  
 durch eine greiche der gewöhnlichen  
 Art, eine greiche der gewöhnlichen  
 Kopf der Künst-  
 schreiz strahlte.  
 gerade in  
 entheaters,  
 reiche Af-  
 wenig Ver-  
 h Gute



**Ausstellung**  
**des Deutschen**  
**Künstlerbundes**  
**Mannheim**  
**1 9 1 3**  
**4. Mai - 30. September**

Abb. 98. Lucian Bernhard: Ausstellungs-Plakat  
 (zu Seite 91)

zu  
 Hollerbaum & Schmidt hinzugetreten  
 sind, nenne ich H. R. Erdt, der in  
 München mit ein paar zu guten Er-  
 wartungen berechtigenden Arbeiten  
 hervorgetreten war, gegenüber den  
 Anforderungen des Berliner Groß-  
 abtplakates aber ziemlich versagt  
 t, und vor allem Paul Scheurich.  
 ne Blätter gehen zum großen Teile  
 ie Provinz; in Berlin sieht man



# Accademia

*... e un attimo dopo fu accanto alla baronessa Anna che già afferrava la maniglia della porta.*

*“Perdoni! disse sottovoce, quasi che nessun altro degli astanti fosse degno di udirla. Ecco l’anello”.*

*Così dicendo ficcò l’anello di Harry in mano alla baronessa; e questa tutt’a un tratto su quella stessa mano sentì il visetto largo e acceso della ragazza.*

*E una felicità, una soave, calda, arcana felicità le fece per un attimo chiudere gli occhi ...*

*Thomas Mann,  
Felicità (1904)*

*... and a moment later he was already next to the Baroness Anna that was already grabbing the door handle.*

*“Excuse me! He said softly, almost no one else of the bystanders was worthy to hear it. Here is the ring”.*

*So saying, he shoved the Harry ring in hand to the baroness, and all of a sudden he felt on the same hand that little wide and flushed face of the girl.*

*And a happiness, a gentle, warm, mysterious happiness made her close her eyes for a moment ...*

*Thomas Mann,  
Bashan and I (1904)*

# Accademia

maniglie per porta su placca e rosetta  
door handles on plate and on rose

materiale: ottone  
material: brass

**KAC11 PB70**  
**KAC11 PB90**  
**KAC11 PBY85**

Ottone naturale non verniciato  
Natural brass not lacquered

Bronzo non verniciato  
Bronze not lacquered

Argento naturale non verniciato  
Natural silver not lacquered

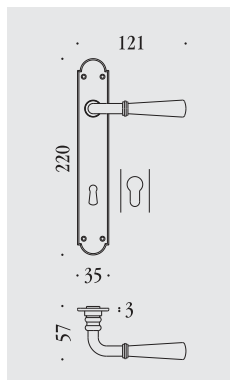

**KAC11 PBX70**  
**KAC11 PBX90**  
**KAC11 PBY85**

Ottone naturale non verniciato  
Natural brass not lacquered

Bronzo non verniciato  
Bronze not lacquered

Argento naturale non verniciato  
Natural silver not lacquered

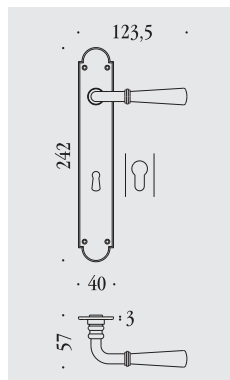

**KAC11 RB**  
**KAC11 RBY**

Ottone naturale non verniciato  
Natural brass not lacquered

Bronzo non verniciato  
Bronze not lacquered

Argento naturale non verniciato  
Natural silver not lacquered

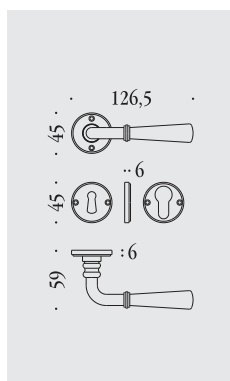

**KAC11 R**  
**KAC11 RY**

Ottone naturale non verniciato  
Natural brass not lacquered

Bronzo non verniciato  
Bronze not lacquered

Argento naturale non verniciato  
Natural silver not lacquered

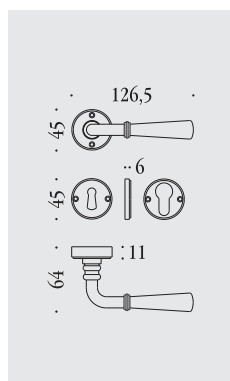

**KAC11 RBO**  
**KAC11 RBOY**

Ottone naturale non verniciato  
Natural brass not lacquered

Bronzo non verniciato  
Bronze not lacquered

Argento naturale non verniciato  
Natural silver not lacquered

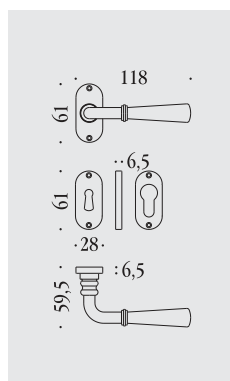

**KAC13 BP - KAC13 BY**  
**KAC19 BZG 6B**

Ottone naturale non verniciato  
Natural brass not lacquered

Bronzo non verniciato  
Bronze not lacquered

Argento naturale non verniciato  
Natural silver not lacquered

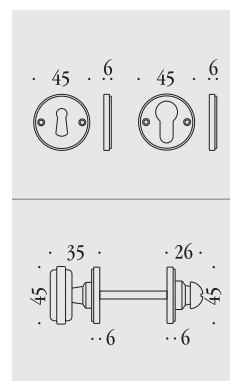

# Accademia



Ottone naturale non verniciato  
Natural brass not lacquered



Bronzo non verniciato  
Bronze not lacquered



Argento naturale non verniciato  
Natural silver not lacquered

# Accademia

maniglie per finestra e per dreh-kipp  
window and dreh-kipp handles

materiale: ottone  
material: brass

## KAC12 B

Ottone naturale non verniciato  
Natural brass not lacquered

Bronzo non verniciato  
Bronze not lacquered

Argento naturale non verniciato  
Natural silver not lacquered

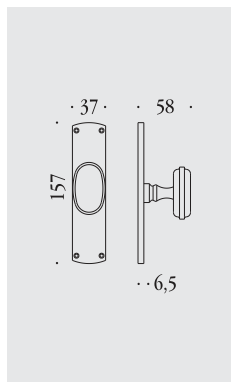

## KAC12

Ottone naturale non verniciato  
Natural brass not lacquered

Bronzo non verniciato  
Bronze not lacquered

Argento naturale non verniciato  
Natural silver not lacquered

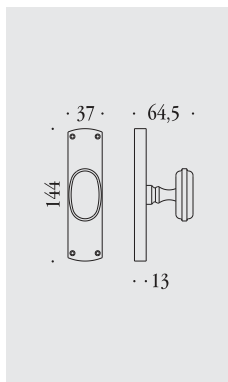

## KAC12 CRDK

Ottone naturale non verniciato  
Natural brass not lacquered

Bronzo non verniciato  
Bronze not lacquered

Argento naturale non verniciato  
Natural silver not lacquered

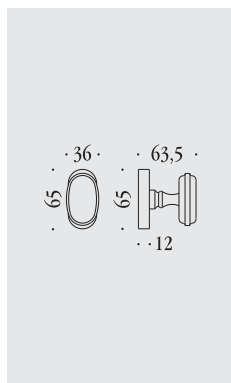

## KAC12 DK/SM

Ottone naturale non verniciato  
Natural brass not lacquered

Bronzo non verniciato  
Bronze not lacquered

Argento naturale non verniciato  
Natural silver not lacquered

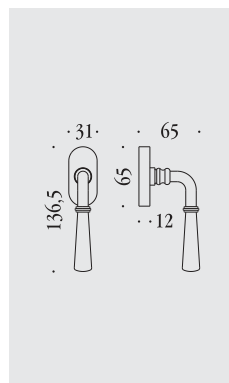



Ottone naturale non verniciato  
Natural brass not lacquered



Ottone naturale non verniciato  
Natural brass not lacquered



Argento naturale non verniciato  
Natural silver not lacquered



# Barocco

*... se non mostrerà le ricchissime  
spoglie, e le prede, le sarisse,  
le faretre, gli elmi, gli scudi,  
i vasi d'oro e d'argento;  
le maniglie, gli anelli,  
i guenimenti di cavallo, e gli altri  
doni militari; ...*

*Torquato Tasso,  
Colle Controversie sulla Gerusalemme (1823)*

*... if he won't show his glorious  
remains, his conquered catches,  
with his lances, his backpack  
containers filled with arrows, his  
shields, helmets, silver and golden  
vases; handles, rings, horse  
sufferance sounds, and all the  
war gifts; ...*

*Torquato Tasso,  
Colle Controversie sulla Gerusalemme (1823)*

# Barocco

*maniglie per porta su placca e rosetta*  
*door handles on plate and on rose*

*materiale: ottone*  
*material: brass*

**KBA11 P70**  
**KBA11 P90**  
**KBA11 PY85**

Ottone naturale non verniciato  
 Natural brass not lacquered

Bronzo non verniciato  
 Bronze not lacquered

Argento naturale non verniciato  
 Natural silver not lacquered

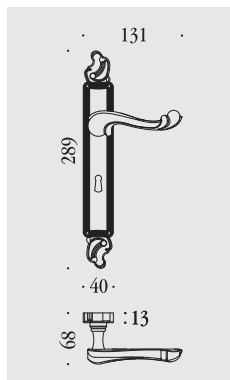

**KBA11 R**  
**KBA11 RY**

Ottone naturale non verniciato  
 Natural brass not lacquered

Bronzo non verniciato  
 Bronze not lacquered

Argento naturale non verniciato  
 Natural silver not lacquered

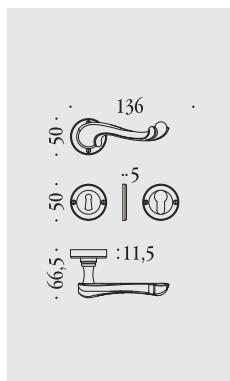

**KBA13 P - KBA13 Y**  
**KBA19 BZG 6G**

Ottone naturale non verniciato  
 Natural brass not lacquered

Bronzo non verniciato  
 Bronze not lacquered

Argento naturale non verniciato  
 Natural silver not lacquered

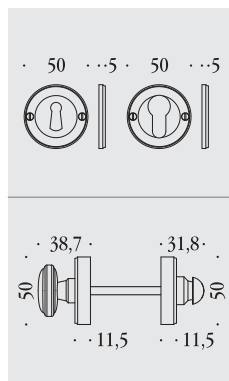



# Barocco



Ottone naturale non verniciato  
Natural brass not lacquered



Bronzo non verniciato  
Bronze not lacquered



Argento naturale non verniciato  
Natural silver not lacquered

# Barocco

*maniglie per finestra e per dreh-kipp  
window and dreh-kipp handles*

*materiale: ottone  
material: brass*

## **KBA12**

Ottone naturale non verniciato  
Natural brass not lacquered

Bronzo non verniciato  
Bronze not lacquered

Argento naturale non verniciato  
Natural silver not lacquered

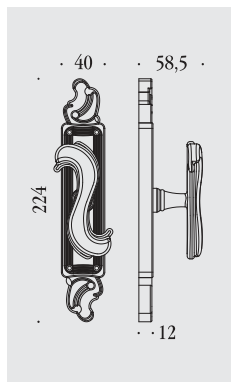

## **KBA12 CRDK**

Ottone naturale non verniciato  
Natural brass not lacquered

Bronzo non verniciato  
Bronze not lacquered

Argento naturale non verniciato  
Natural silver not lacquered

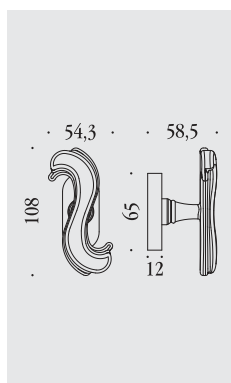

## **KBA12 DK/SM**

Ottone naturale non verniciato  
Natural brass not lacquered

Bronzo non verniciato  
Bronze not lacquered

Argento naturale non verniciato  
Natural silver not lacquered

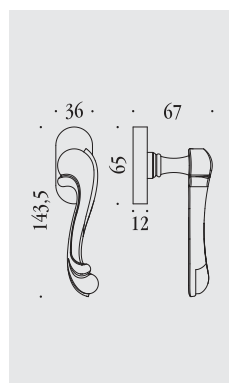

# *Barocco*



Ottone naturale non verniciato  
Natural brass not lacquered



Bronzo non verniciato  
Bronze not lacquered



Argento naturale non verniciato  
Natural silver not lacquered

... auf ei...  
... des Lebens zu lösen, die  
... so gut wie unbekannt  
... zarten Geistes umfängt —  
... ein Genies schwebt herauf  
... christlichen Gewande, eine Dornenkrone  
... das in lei...  
... hat. Ein großer Teil sein  
... des Publikums so überaus  
... der eben besprochenen Um...  
... als die Berliner Plakat-  
... lebte eines Tages  
... das, zumal in  
... große Wahrheit, in Gestalt einer zierlichen  
... Philister im buch-  
... aufgerissenen Blöhaugen.  
... Hartmanns „Karma“ — ein Teil der  
... als Vertörperung des Lebens  
... (Abb. 84 u. 85).  
... durch das Eingreifen einer tatkräftigen  
... Im Herbst 1897 lebte  
... Karl Schwebel, das  
... Da sprang die große Wahrheit, in Gestalt einer zierlichen  
... unheimlich dreinschauenden  
... stumpfsinnig  
... vor Erstaunen weit aufgerissenen Blöhaugen.  
... als ein lustiges Plakat von Karl Schwebel, das  
... Da sprang die große Wahrheit, in Gestalt einer zierlichen  
... unheimlich dreinschauenden  
... stumpfsinnig  
... vor Erstaunen weit aufgerissenen Blöhaugen.  
... als ein lustiges Plakat von Karl Schwebel, das  
... Da sprang die große Wahrheit, in Gestalt einer zierlichen  
... unheimlich dreinschauenden  
... stumpfsinnig  
... vor Erstaunen weit aufgerissenen Blöhaugen.



Abb. 74. Theodor Heine: Plakat für die dritte Kunstausstellung der Berliner Secession (W. Filbers Kunstverlag, Berlin) (zu Seite 74)



# Bellagio

*Entrarono in una sala di dove si accedeva direttamente nell'appartamento del principe Vassilij.*

*Mentre madre e figlio, fermi in mezzo alla sala, si accingevano ad interrogare un vecchio domestico che al loro ingresso si era alzato da uno sgabello, si mosse la maniglia di bronzo di una delle porte, e il principe Vassilij in giacca di velluto da casa, con una sola decorazione, uscì, accompagnando un bell'uomo dai capelli neri. Era questi Lorrain, il famoso medico di Pietroburgo.*

*Lev Nicoàevic Tolstòj,  
Guerra e Pace (1863)*

*They entered the large hall, from which one of the doors led to the apartments assigned to Prince Vasili.*

*Just as the mother and son, having reached the middle of the hall, were about to ask their way of an elderly footman who had sprung up as they entered, the bronze handle of one of the doors turned and Prince Vasili came out - wearing a velvet coat with a single star on his breast, as his custom when at home - taking leave of a good-looking, dark-haired man. This was the celebrated Petersburg doctor, Lorrain.*

*Lev Nicoàevic Tolstòj,  
War and peace (1863)*

# Bellagio

*maniglie per porta su placca e rosetta*  
*door handles on plate and on rose*

*materiale: ottone*  
*material: brass*

**KBE11 PB70**  
**KBE11 PB90**  
**KBE11 PBY85**

Ottone naturale non verniciato  
 Natural brass not lacquered

Bronzo non verniciato  
 Bronze not lacquered

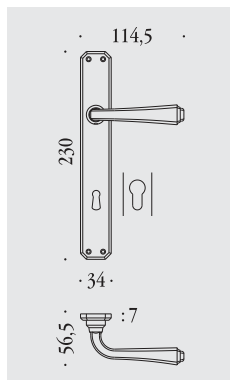

**KBE11 RB**  
**KBE11 RBY**

Ottone naturale non verniciato  
 Natural brass not lacquered

Bronzo non verniciato  
 Bronze not lacquered

Cromo  
 Chrome

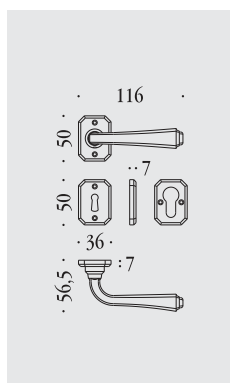

**KBE13 BP - KBE13 BY**  
**KBU19 BZG 6B**

Ottone naturale non verniciato  
 Natural brass not lacquered

Bronzo non verniciato  
 Bronze not lacquered

Cromo  
 Chrome

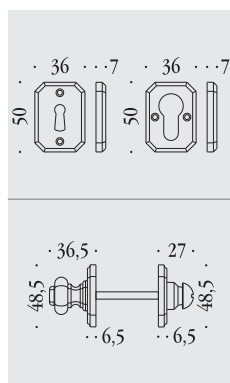

# *Bellagio*



Ottone naturale non verniciato  
Natural brass not lacquered



Bronzo non verniciato  
Bronze not lacquered



Cromo  
Chrome

# Bellagio

maniglie per finestra e per dreh-kipp  
window and dreh-kipp handles

materiale: ottone  
material: brass

## **KBE12 B**

Ottone naturale non verniciato  
Natural brass not lacquered

Bronzo non verniciato  
Bronze not lacquered

Cromo  
Chrome

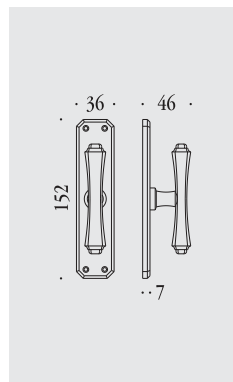

## **KBE12**

Ottone naturale non verniciato  
Natural brass not lacquered

Bronzo non verniciato  
Bronze not lacquered

Cromo  
Chrome

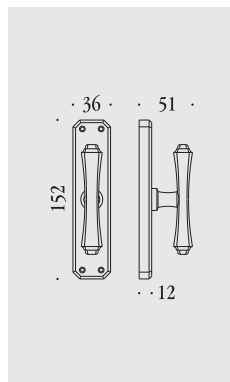

## **KBE12 DK/SM**

Ottone naturale non verniciato  
Natural brass not lacquered

Bronzo non verniciato  
Bronze not lacquered

Cromo  
Chrome

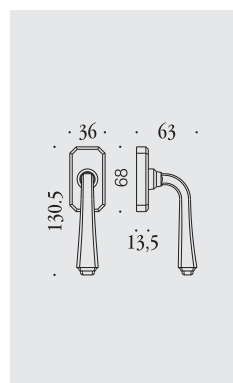



# *Bellagio*



Ottone naturale non verniciato  
Natural brass not lacquered



Bronzo non verniciato  
Bronze not lacquered



Cromo  
Chrome



# Busiri

*"Grazie, lui mi conosce",  
disse Scrooge, che aveva già la  
mano sulla maniglia della sala  
da pranzo. "Entrerò qui, mia cara."  
Fece girare la maniglia pian piano,  
e si affacciò alla porta semiaperta.  
Stavano guardando la tavola  
apparecchiata con un gran lusso,  
perché i padroni di casa, quando  
sono giovani, sono sempre nervosi  
su questo punto e vogliono esser  
sicuri che tutto sia in perfetto  
ordine.*

*Charles Dickens,  
Un canto di natale (1843)*

*"Thank'ee. He knows me",  
said Scrooge, with his hand  
already on the dining-room lock.  
"I'll go in here, my dear."  
He turned the handle gently, and  
sidled his face in, round the door.  
They were looking at the table  
(which was spread out in great  
array); for these young  
housekeepers are always nervous  
on such points, and like to see that  
everything is right.*

*Charles Dickens,  
A Christmas Carol (1843)*

# Busiri

*maniglie per porta su placca e rosetta*  
*door handles on plate and on rose*

*materiale: ottone*  
*material: brass*

## **KBU11 P70**

## **KBU11 P90**

## **KBU11 PY85**

Ottone naturale non verniciato  
 Natural brass not lacquered

Bronzo non verniciato  
 Bronze not lacquered

Argento naturale non verniciato  
 Natural silver not lacquered

Cromo  
 Chrome

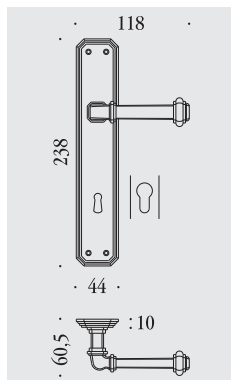

## **KBU11 R** **KBU11 RY**

Ottone naturale non verniciato  
 Natural brass not lacquered

Bronzo non verniciato  
 Bronze not lacquered

Argento naturale non verniciato  
 Natural silver not lacquered

Cromo  
 Chrome

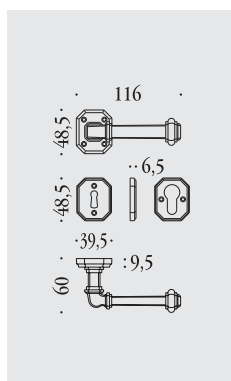

## **KBU13 BP - KBU13 BY** **KBU19 BZG 6B**

Ottone naturale non verniciato  
 Natural brass not lacquered

Bronzo non verniciato  
 Bronze not lacquered

Argento naturale non verniciato  
 Natural silver not lacquered

Cromo  
 Chrome

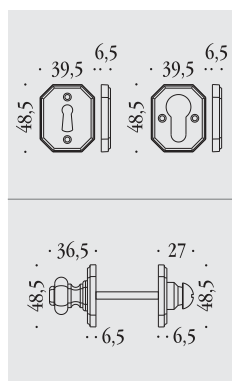



Ottone naturale non verniciato  
Natural brass not lacquered



Bronzo non verniciato  
Bronze not lacquered



Argento naturale non verniciato  
Natural silver not lacquered



Cromo  
Chrome

# Busiri

maniglie per finestra e per dreh-kipp  
window and dreh-kipp handles

materiale: ottone  
material: brass

## **KBU12 B**

Ottone naturale non verniciato  
Natural brass not lacquered

Bronzo non verniciato  
Bronze not lacquered

Argento naturale non verniciato  
Natural silver not lacquered

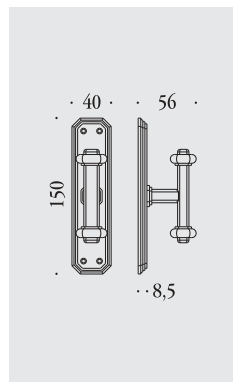
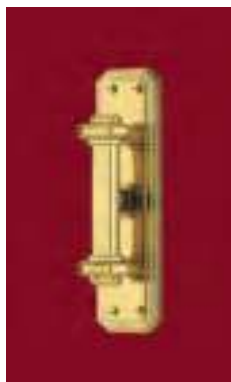

## **KBU12**

Ottone naturale non verniciato  
Natural brass not lacquered

Bronzo non verniciato  
Bronze not lacquered

Argento naturale non verniciato  
Natural silver not lacquered

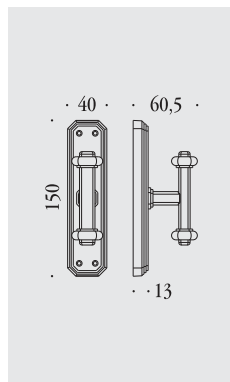

## **KBU12 DK/SM**

Ottone naturale non verniciato  
Natural brass not lacquered

Bronzo non verniciato  
Bronze not lacquered

Argento naturale non verniciato  
Natural silver not lacquered

Cromo  
Chrome

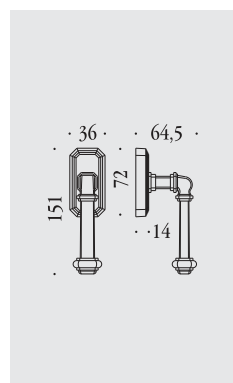



Ottone naturale non verniciato  
Natural brass not lacquered



Argento naturale non verniciato  
Natural silver not lacquered





# Byblos

*“È una donna”, lo fermò, le dita  
aggrappate alla maniglia, gli occhi  
spalancati.*

*Egli sentiva tutto il suo antico  
animo filiale ribellarsi in quella  
immobilità e tirarlo indietro;  
ma quello nuovo, ancora timido,  
eppure già forte, lo costringeva a  
fissare spietatamente  
gli occhi riluttanti là dove il giorno  
prima non avrebbe osato levarli.*

*Alberto Moravia,  
Agostino (1944)*

*“Is a woman”, he stopped him,  
fingers gripping the handle,  
eyes wide.*

*He felt all his former rebel in the  
soul of a child still coming back;  
but the new one, still shy, but  
already strong, forcing him to fix  
his eyes fiercely reluctant to where  
the day before would not have  
dared to remove them.*

*Alberto Moravia,  
Agostino (1944)*

# Byblos

*maniglie per porta su placca e rosetta*  
*door handles on plate and on rose*

*materiale: ottone*  
*material: brass*

## **KBY11 P70**

## **KBY11 P90**

## **KBY11 PY85**

Ottone lucido verniciato  
 Lacquered polished brass

Bronzo satinato verniciato  
 Lacquered satin bronze

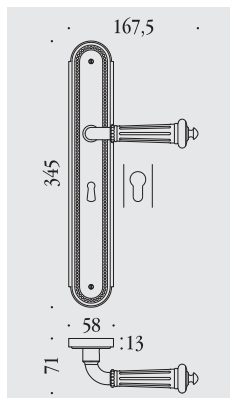

## **KBY11 R**

## **KBY11 RY**

Ottone lucido verniciato  
 Lacquered polished brass

Bronzo satinato verniciato  
 Lacquered satin bronze

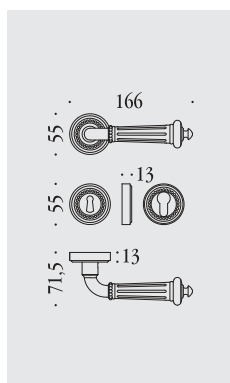

## **KBY13 P - KBY13 Y**

## **KBY19 BZG 6GB**

Ottone lucido verniciato  
 Lacquered polished brass

Bronzo satinato verniciato  
 Lacquered satin bronze

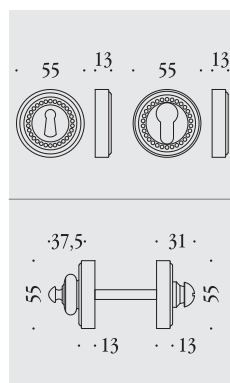

# Byblos



Ottone lucido verniciato  
Lacquered polished brass



Bronzo satinato verniciato  
Lacquered satin bronze

# Byblos

maniglie per finestra e per dreh-kipp  
window and dreh-kipp handles

materiale: ottone  
material: brass

## **KBY12**

Ottone lucido verniciato  
Lacquered polished brass

Bronzo satinato verniciato  
Lacquered satin bronze

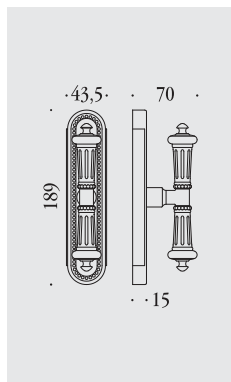

## **KBY12 CRDK**

Ottone lucido verniciato  
Lacquered polished brass

Bronzo satinato verniciato  
Lacquered satin bronze

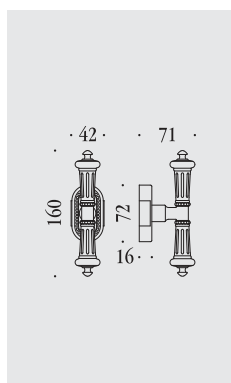

## **KBY12 DK/SM**

Ottone lucido verniciato  
Lacquered polished brass

Bronzo satinato verniciato  
Lacquered satin bronze

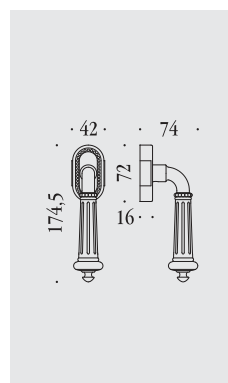



Ottone lucido verniciato  
Lacquered polished brass



Ottone lucido verniciato  
Lacquered polished brass



Ottone lucido verniciato  
Lacquered polished brass



PIERRE  
MAGNE

CAPRI.

PIERRE IN THE ROYAL COLLECTION

LONDRES, PURCHASED FOR THE PROPRIETARY

# Capri

*Lo ripose quasi con dispiacere fra  
le pagine, chiuse il libro e lo  
ricollocò sullo sgabello.  
Era tempo: la maniglia della porta  
girò ed un uomo si fece innanzi,  
camminando lentamente e con  
quella rigidità che è particolare  
agli uomini di razza anglosassone.*

*Emilio Salgari,  
Le tigri di Mompracen (1900)*

*He put it back with displeasure  
between the pages, he closed the book  
and he relocated it on the stool.  
It was time: the door handle turned  
and a man came forward, walking  
slowly and with a stiffness that is  
typical of the men of the  
Anglo-Saxon race.*

*Emilio Salgari,  
Le tigri di Mompracen (1900)*

# Capri

maniglie per porta su rosetta  
door handles on rose

materiale: ottone  
material: brass

## ***KCR11 RB*** ***KCR11 RBY***

Ottone naturale non verniciato  
Natural brass not lacquered

Bronzo non verniciato  
Bronze not lacquered

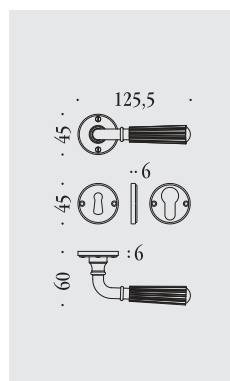
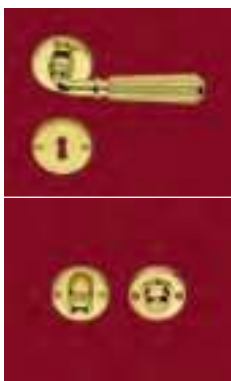

## ***KAC13 BP - KAC13 BY*** ***KCR19 BZG 6B***

Ottone naturale non verniciato  
Natural brass not lacquered

Bronzo non verniciato  
Bronze not lacquered

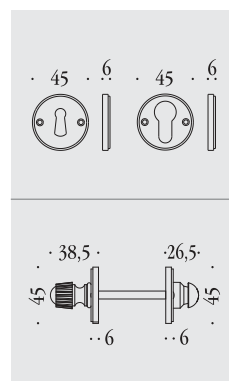





Ottone naturale non verniciato  
Natural brass not lacquered



Bronzo non verniciato  
Bronze not lacquered

# Capri

maniglie per finestra e per dreh-kipp  
window and dreh-kipp handles

materiale: ottone  
material: brass

## KCR12 B

Ottone naturale non verniciato  
Natural brass not lacquered

Bronzo non verniciato  
Bronze not lacquered

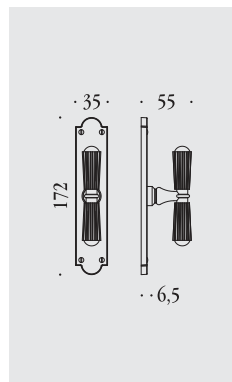

## KCR12

Ottone naturale non verniciato  
Natural brass not lacquered

Bronzo non verniciato  
Bronze not lacquered

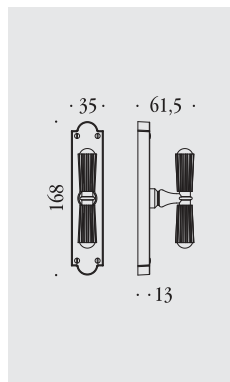

## KCR12 CRDK

Ottone naturale non verniciato  
Natural brass not lacquered

Bronzo non verniciato  
Bronze not lacquered

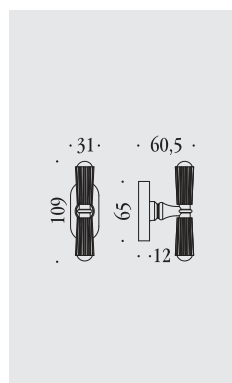

## KCR12 DK/SM

Ottone naturale non verniciato  
Natural brass not lacquered

Bronzo non verniciato  
Bronze not lacquered

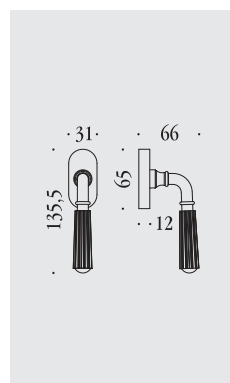



Ottone naturale non verniciato  
Natural brass not lacquered



Bronzo non verniciato  
Bronze not lacquered



Ottone naturale non verniciato  
Natural brass not lacquered

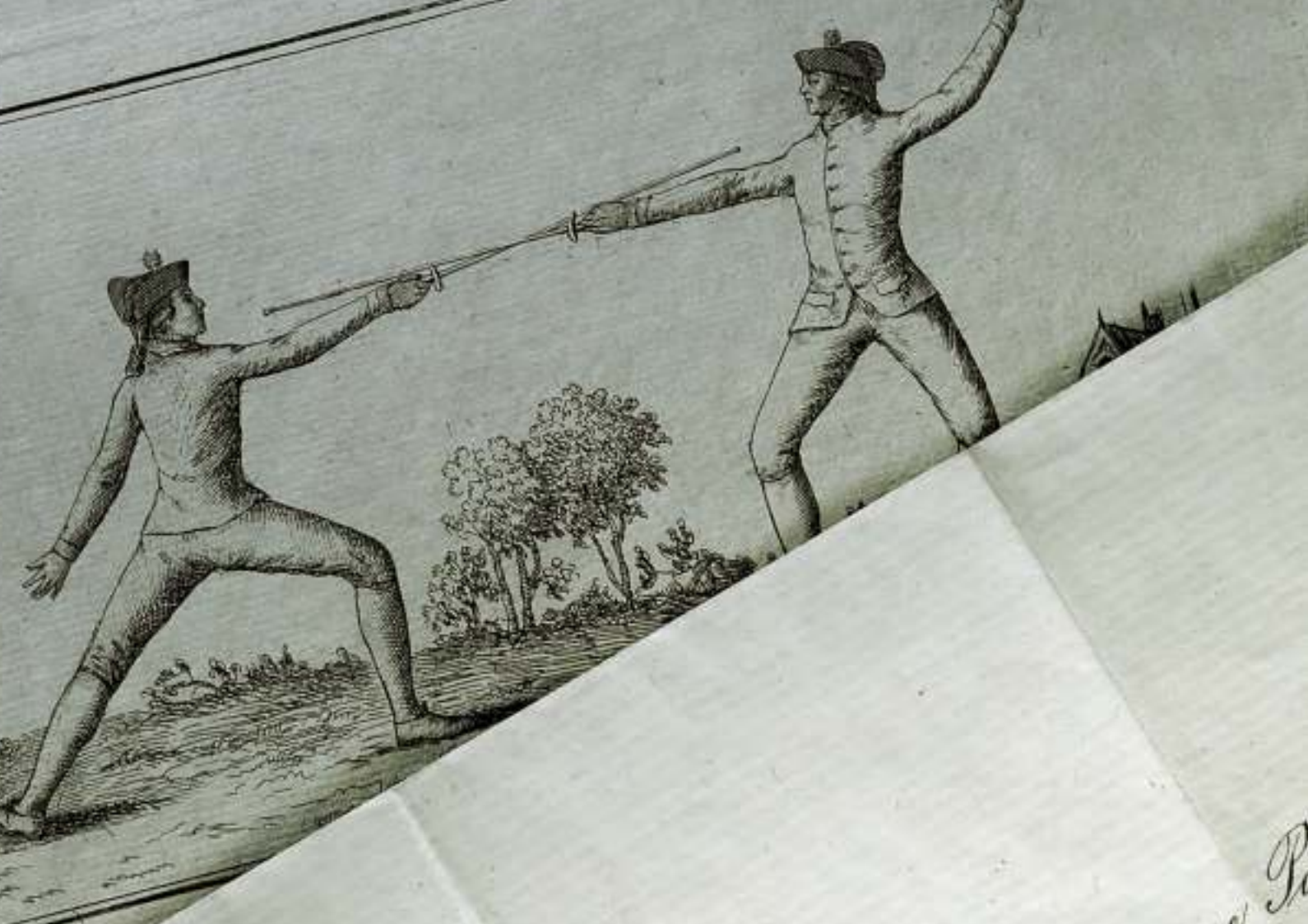

Consolati di Heiligenbrunn e P  
Cavaliere dell' I. R. Ordine Aust  
Consolati nata Baron  
iminer  
Dottore  
Hoh  
Hoh  
Car. de  
Bacciatore  
Cidi, A

cenzo  
ile provincial  
na ferrea, ed  
Lilienberg e  
Ferdinando  
Bianca Contessa de Thun-  
Guidobaldo de Thun-  
M. J. R. Apost.  
Hran Cacciatore

# Firenze

*Era una specie di iniziazione alla vita, l'accesso ai piaceri proibiti; entrando posava la mano sulla maniglia della porta con un piacere quasi sensuale.*

*E allora molti lati nascosti del suo carattere si rivelarono: imparò canzonacce che cantava durante le bevute, si entusiasmò per Béranger, imparò a prepararsi il ponce e infine conobbe l'amore.*

*Gustave Flaubert,  
Madame Bovary (1856)*

*It was beginning to see life, the sweetness of stolen pleasures; and when he entered, he put his hand on the door-handle with a joy almost sensual.*

*Then many things hidden within him came out; he learnt couplets by heart and sang them to his boon companions, became enthusiastic about Beranger, learnt how to make punch, and finally, how to make love.*

*Gustave Flaubert,  
Madame Bovary (1856)*

# Firenze

*maniglie per porta su placca e rosetta*  
*door handles on plate and on rose*

*materiale: ottone*  
*material: brass*

## **KOT21 PB70**

## **KOT21 PB90**

## **KOT21 PBY85**

Ottone naturale non verniciato  
 Natural brass not lacquered

Bronzo non verniciato  
 Bronze not lacquered

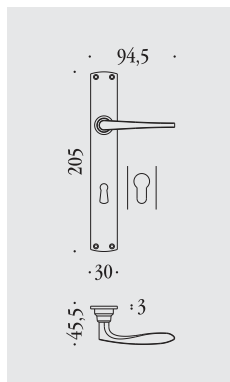

## **KOT21 RB**

## **KOT21 RBY**

Ottone naturale non verniciato  
 Natural brass not lacquered

Bronzo non verniciato  
 Bronze not lacquered

Nichel naturale non verniciato  
 Natural nickel not lacquered

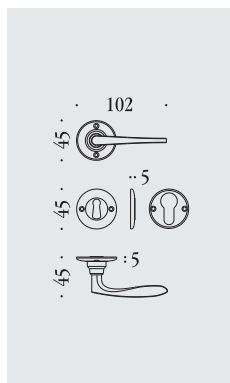

## **KOT21 RBO**

## **KOT21 RBOY**

Ottone naturale non verniciato  
 Natural brass not lacquered

Bronzo non verniciato  
 Bronze not lacquered

Nichel naturale non verniciato  
 Natural nickel not lacquered

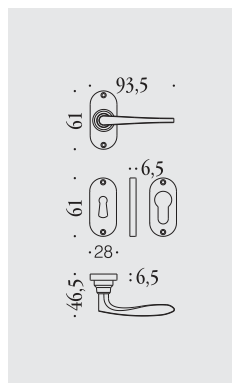

## **KOT13 BP - KOT13 BY**

## **KOT19 BZG 6B**

Ottone naturale non verniciato  
 Natural brass not lacquered

Bronzo non verniciato  
 Bronze not lacquered

Nichel naturale non verniciato  
 Natural nickel not lacquered

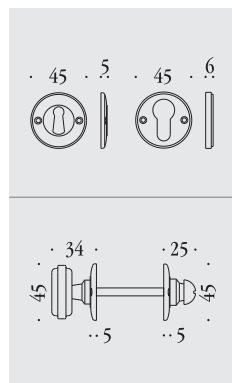



Ottone naturale non verniciato  
Natural brass not lacquered



Bronzo non verniciato  
Bronze not lacquered



Nichel naturale non verniciato  
Natural nickel not lacquered

# Firenze

*maniglie per finestra e per dreh-kipp  
window and dreh-kipp handles*

*materiale: ottone  
material: brass*

## **KOT22 B**

Ottone naturale non verniciato  
Natural brass not lacquered

Bronzo non verniciato  
Bronze not lacquered

Nichel naturale non verniciato  
Natural nickel not lacquered

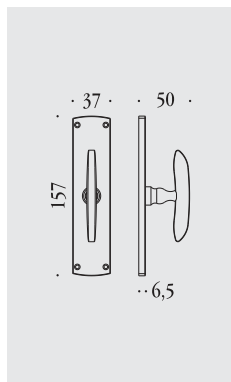

## **KOT22 CRDK**

Ottone naturale non verniciato  
Natural brass not lacquered

Bronzo non verniciato  
Bronze not lacquered

Nichel naturale non verniciato  
Natural nickel not lacquered

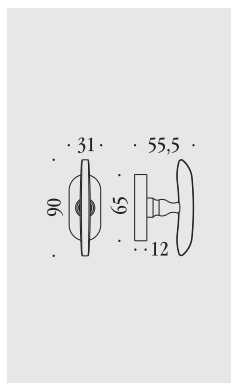

## **KOT22 DK/SM**

Ottone naturale non verniciato  
Natural brass not lacquered

Bronzo non verniciato  
Bronze not lacquered

Argento naturale non verniciato  
Natural silver not lacquered

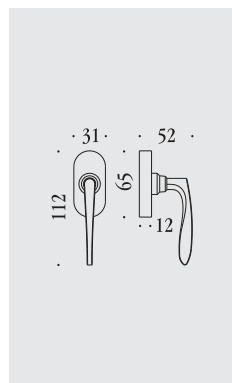





Ottone naturale non verniciato  
Natural brass not lacquered



Ottone naturale non verniciato  
Natural brass not lacquered



Nichel naturale non verniciato  
Natural nickel not lacquered



# Impero

*Si udì la sua mano tentar un uscio,  
girar una maniglia.*

*Una lama di luce brillò nel  
corridoio ... Entrarono.*

*V'erano candele accese sulla  
ribalta calata dello stipò, sul piano  
aperto, sopra una libreria bassa.*

*Dalla porta spalancata della  
camera da letto entrava pure un  
debole chiarore.*

*Grandi mazzi sciolti di glicine  
celesti, di rose bianche e gialle  
erano sparsi un po' dappertutto ...*

*Antonio Fogazzaro,  
Malombra (1881)*

*You heard bis hand groped a door,  
turn a handle.*

*A sliver of light shone in the hall. . .  
They entered.*

*There were candles lit on stage on  
open cabinet over a low bookcase.*

*From the open door of the bedroom  
came a faint glow as well.*

*Large loose clusters of wisteria blue,  
yellow and white roses were scattered  
almost everywhere ...*

*Antonio Fogazzaro,  
The Woman (1881)*

# Impero

maniglie per porta su placca e rosetta  
door handles on plate and on rose

materiale: ottone  
material: brass

**KIM11 PB70**  
**KIM11 PB90**  
**KIM11 PBY85**

Ottone naturale non verniciato  
Natural brass not lacquered

Bronzo non verniciato  
Bronze not lacquered

Argento naturale non verniciato  
Natural silver not lacquered

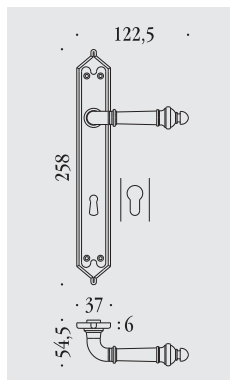

**KIM11 R**  
**KIM11 RY**

Ottone naturale non verniciato  
Natural brass not lacquered

Bronzo non verniciato  
Bronze not lacquered

Argento naturale non verniciato  
Natural silver not lacquered

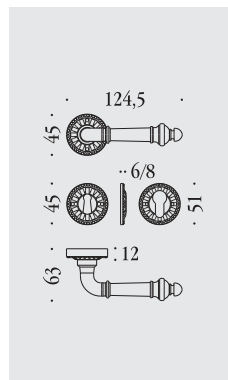

**KIM11 RB**  
**KIM11 RBY**

Ottone naturale non verniciato  
Natural brass not lacquered

Bronzo non verniciato  
Bronze not lacquered

Argento naturale non verniciato  
Natural silver not lacquered

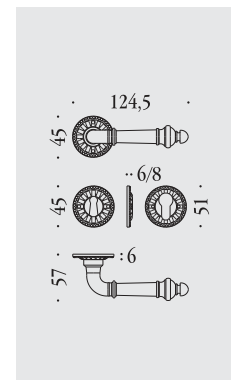

## Impero Grande

**KIM11 RG**  
**KIM11 RGY**

Ottone naturale non verniciato  
Natural brass not lacquered

Bronzo non verniciato  
Bronze not lacquered

Argento naturale non verniciato  
Natural silver not lacquered

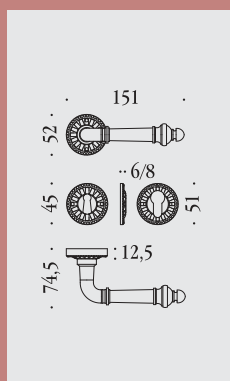

**KIM11 RB0**  
**KIM11 RB0Y**

Ottone naturale non verniciato  
Natural brass not lacquered

Bronzo non verniciato  
Bronze not lacquered

Argento naturale non verniciato  
Natural silver not lacquered

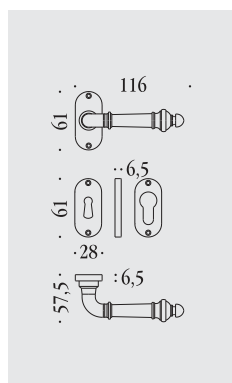

**KLU13 BP - KLU13 BY**

Ottone naturale non verniciato  
Natural brass not lacquered

Bronzo non verniciato  
Bronze not lacquered

Argento naturale non verniciato  
Natural silver not lacquered

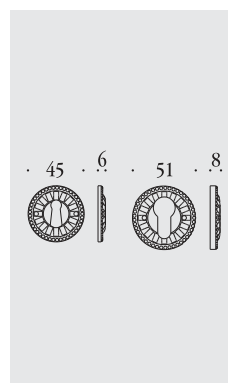

**KIM19 BZG 6B**  
**KIM19 BZG 6GB**

Ottone naturale non verniciato  
Natural brass not lacquered

Bronzo non verniciato  
Bronze not lacquered

Argento naturale non verniciato  
Natural silver not lacquered

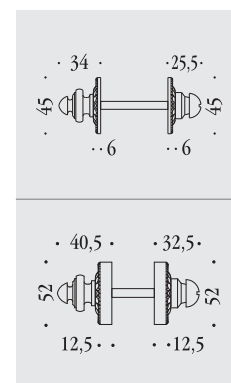



Ottone naturale non verniciato  
Natural brass not lacquered



Bronzo non verniciato  
Bronze not lacquered



Argento naturale non verniciato  
Natural silver not lacquered

# Impero

maniglie per finestra e per dreh-kipp  
window and dreh-kipp handles

materiale: ottone  
material: brass

## KIM12 B

Ottone naturale non verniciato  
Natural brass not lacquered

Bronzo non verniciato  
Bronze not lacquered

Argento naturale non verniciato  
Natural silver not lacquered

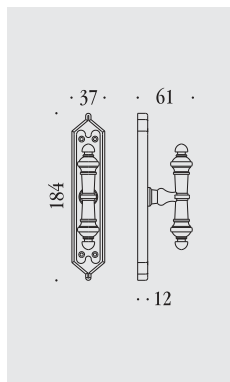

## KIM12

Ottone naturale non verniciato  
Natural brass not lacquered

Bronzo non verniciato  
Bronze not lacquered

Argento naturale non verniciato  
Natural silver not lacquered

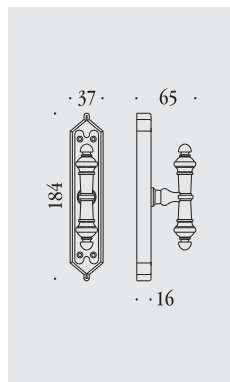

## KIM12 CRDK

Ottone naturale non verniciato  
Natural brass not lacquered

Ottone lucido verniciato  
Lacquered polished brass

Bronzo non verniciato  
Bronze not lacquered

Bronzo verniciato  
Lacquered bronze

Argento naturale non verniciato  
Natural silver not lacquered

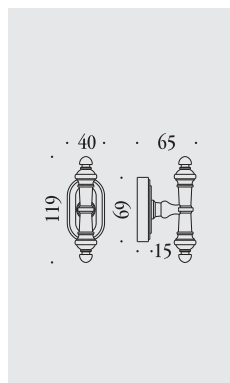

## KIM12 DK/SM

Ottone naturale non verniciato  
Natural brass not lacquered

Ottone lucido verniciato  
Lacquered polished brass

Bronzo non verniciato  
Bronze not lacquered

Bronzo verniciato  
Lacquered bronze

Argento naturale non verniciato  
Natural silver not lacquered

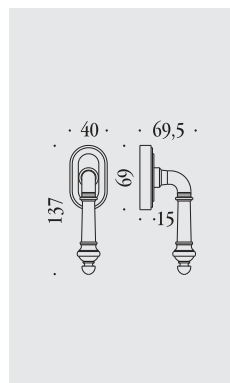



Ottone naturale non verniciato  
Natural brass not lacquered



Ottone naturale non verniciato  
Natural brass not lacquered



Argento naturale non verniciato  
Natural silver not lacquered



MARIE  
ANTOINETTE-CHANTAL  
REINE DE FRANCE

LETTRES  
CHOISIES  
DE M<sup>ES</sup> DE SÉVIGNE,  
DE GRIGNAN, DE SIMIANE,  
ET DE MAINTENON;  
Avec des RÉFLEXIONS de M. l'Abbé DE  
M. GROUVELLE.

PREMIER.

PARIS  
BOSSANGE et BASSON, Imp.-Libr., rue de Tournai, n° 6.  
1817.





# Lidia

*Stava là sulla soglia, stupito,  
con una mano sulla maniglia della  
porta socchiusa, con la testa un po'  
china innanzi e oscillante,  
col corpo avvolto in una veste da  
camera bianca diritta e senza  
pieghe come un ...*

*Victor Hugo,  
I miserabili (1862)*

*She stood astonished on the  
threshold, one hand on the handle  
of the half- open door, with his head  
bent a little forward and quivering,  
his body wrapped in a white  
dressing-gown, which was straight  
and as destitute of ...*

*Victor Hugo,  
Les Misérables (1862)*

# Lidia

*maniglie per porta su placca e rosetta*  
*door handles on plate and on rose*

materiale: ottone  
 material: brass

**KOT31 P70**  
**KOT31 P90**  
**KOT31 PY85**

Ottone naturale non verniciato  
 Natural brass not lacquered

Bronzo non verniciato  
 Bronze not lacquered

Cromo  
 Chrome

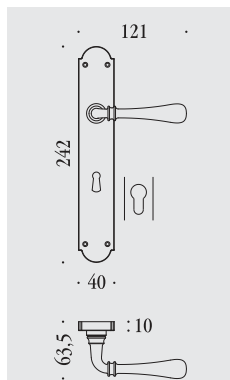

**KOT31 R**  
**KOT31 RY**

Ottone naturale non verniciato  
 Natural brass not lacquered

Bronzo non verniciato  
 Bronze not lacquered

Cromo  
 Chrome

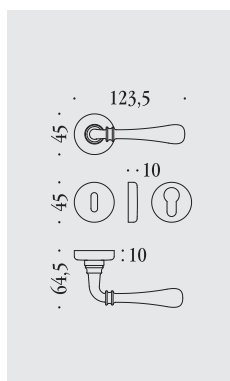

**KOT31 RBO**  
**KOT31 RBOY**

Ottone naturale non verniciato  
 Natural brass not lacquered

Bronzo non verniciato  
 Bronze not lacquered

Cromo  
 Chrome

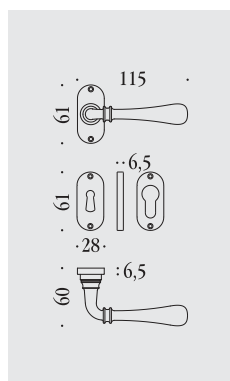

**KOT23 P - KOT23 Y**  
**KOT19 BZG 6B**

Ottone naturale non verniciato  
 Natural brass not lacquered

Bronzo non verniciato  
 Bronze not lacquered

Cromo  
 Chrome

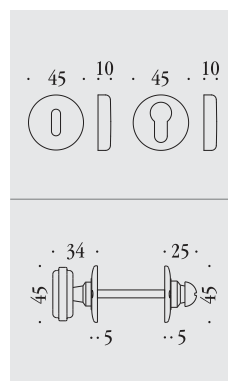



Ottone naturale non verniciato  
Natural brass not lacquered



Bronzo non verniciato  
Bronze not lacquered



Cromo  
Chrome

# Lidia

*maniglie per finestra e per dreh-kipp  
window and dreh-kipp handles*

*materiale: ottone  
material: brass*

## **KOT32**

Ottone naturale non verniciato  
Natural brass not lacquered

Bronzo non verniciato  
Bronze not lacquered

Cromo  
Chrome

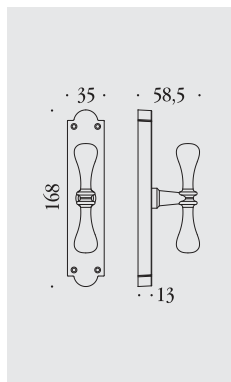

## **KOT32 DK/SM**

Ottone naturale non verniciato  
Natural brass not lacquered

Bronzo non verniciato  
Bronze not lacquered

Cromo  
Chrome

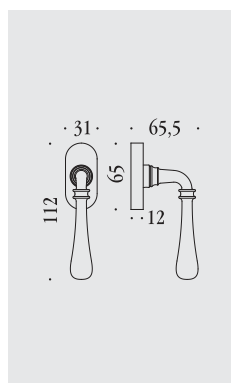



Bronzo non verniciato  
Bronze not lacquered



Cromo  
Chrome

# PIANTA DELLA CITTÀ DI MILANO

publicata nell'anno 1827. \* incisa da Giuseppe Serze.

## DICHIARAZIONE

In questa Pianta sono distinte con tinte variate le Giurisdizioni delle ventitre Parrocchie componenti la Città, essendo particolarmente indicate le Chiese principali le Chiese Subsidiarie cogli Oratorj e le Chiese pubbliche di forte le Chiese Subsidiarie cogli Oratorj e le Chiese aperte al Pubblico con tinta acquarella. Le Chiese pubbliche di Stabilimenti cogli Oratorj aperti al Pubblico sono colorite con la medesima tinta si è ivi tenuta alquanto più risentita, e la stessa preservata per Stabilimenti pubblici.

Sono indicati i perimetri dei quattro Circondarij di Polizia, nei quali è Città, i quali Circondarij sono altresì distinti coi numeri progressivi romani. In tutte le Contrade e Vie si è scritto il nome rispettivo, come pure indicati i corrispondenti numeri civici.

Sono distinti ed indicati tutti gli Stabilimenti pubblici, come pubbliche, e per rendere maggiormente utile la Pianta, si è bene con diverse importanti notizie Statistiche.

Si trova vendibile presso l'Incisore al Ponte di Porta Orientale



Formaj	800	800	800	800
Macellari in genere	1200	1200	1200	1200
Salumieri	1500	1500	1500	1500
Alimentari	1800	1800	1800	1800
Farmazie	2000	2000	2000	2000
Drogherie	2200	2200	2200	2200
Frabificatori di liquori	2500	2500	2500	2500
Stallieri	2800	2800	2800	2800
Altre	3000	3000	3000	3000

Divisione della Città	Colore
I. Ufficio del Comune	Rosso
II. Ufficio del Comune	Giallo
III. Ufficio del Comune	Verde
IV. Ufficio del Comune	Azzurro

Oratorj - Stato Civico del 1826 - Campi Santi

# Louis XVI

*Mi alzai e percorsi il corridoio che  
portava alla stanza dove avevo  
lasciato il Viaggiatore nel tempo.  
Proprio mentre stavo premendo la  
maniglia della porta sentii  
un'esclamazione interrotta, uno  
scatto metallico, un tonfo.  
Nella stanza, un turbinare  
dell'aria, il suono di un cristallo  
che si rompeva sul pavimento.  
Il Viaggiatore e la macchina non  
c'erano più.*

*Herbert George Wells,  
La macchina del tempo (1895)*

*I got up and went down the passage  
to tell the Time Traveller.  
As I took hold of the handle of the  
door I heard an exclamation,  
oddly truncated at the end, and a  
click and a thud.  
A gust of air whirled round me as  
I opened the door,  
and from within came the sound of  
broken glass falling on the floor.  
The Time Traveller was not there.*

*Herbert George Wells,  
The Time Machine (1895)*

# Louis XVI

*maniglie per porta su placca e rosetta*  
*door handles on plate and on rose*

*materiale: ottone*  
*material: brass*

**KLU11 PB70**  
**KLU11 PB90**  
**KLU11 PBY85**

Ottone naturale non verniciato  
 Natural brass not lacquered

Bronzo non verniciato  
 Bronze not lacquered

Argento naturale non verniciato  
 Natural silver not lacquered

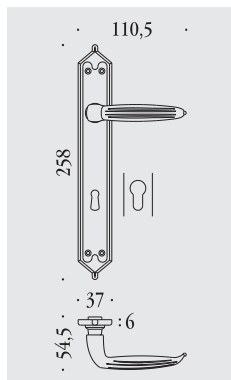

**KLU11 R**  
**KLU11 RY**

Ottone naturale non verniciato  
 Natural brass not lacquered

Bronzo non verniciato  
 Bronze not lacquered

Argento naturale non verniciato  
 Natural silver not lacquered

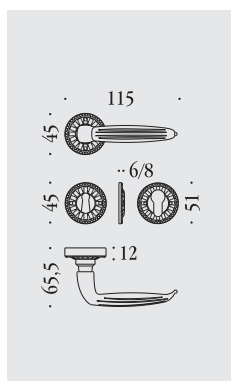

**KLU11 RB**  
**KLU11 RBY**

Ottone naturale non verniciato  
 Natural brass not lacquered

Bronzo non verniciato  
 Bronze not lacquered

Argento naturale non verniciato  
 Natural silver not lacquered

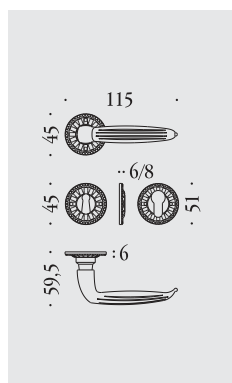

**KLU13 BP - KLU13 BY**  
**KLU19 BZG 6B**

Ottone naturale non verniciato  
 Natural brass not lacquered

Bronzo non verniciato  
 Bronze not lacquered

Argento naturale non verniciato  
 Natural silver not lacquered

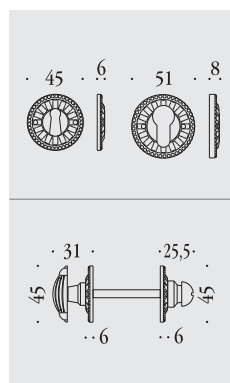



# *Louis XVI*



Ottone naturale non verniciato  
Natural brass not lacquered



Bronzo non verniciato  
Bronze not lacquered



Argento naturale non verniciato  
Natural silver not lacquered

# Louis XVI

maniglie per finestra e per dreh-kipp  
window and dreh-kipp handles

materiale: ottone  
material: brass

## **KLU12 B**

Ottone naturale non verniciato  
Natural brass not lacquered

Bronzo non verniciato  
Bronze not lacquered

Argento naturale non verniciato  
Natural silver not lacquered

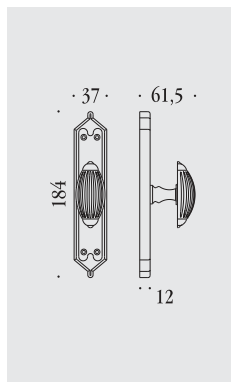

## **KLU12**

Ottone naturale non verniciato  
Natural brass not lacquered

Bronzo non verniciato  
Bronze not lacquered

Argento naturale non verniciato  
Natural silver not lacquered

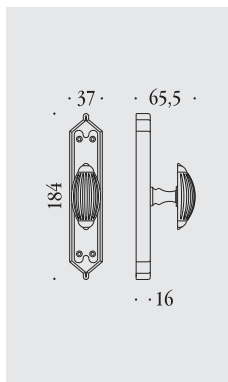

## **KLU12 CRDK**

Ottone naturale non verniciato  
Natural brass not lacquered

Bronzo non verniciato  
Bronze not lacquered

Argento naturale non verniciato  
Natural silver not lacquered

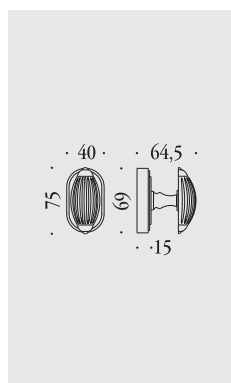

## **KLU12 DK/SM**

Ottone naturale non verniciato  
Natural brass not lacquered

Bronzo non verniciato  
Bronze not lacquered

Argento naturale non verniciato  
Natural silver not lacquered

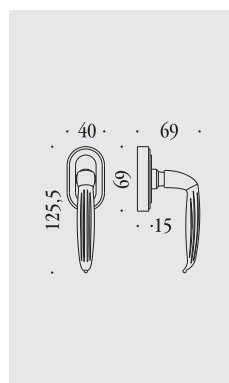

# *Louis XVI*



Ottone naturale non verniciato  
Natural brass not lacquered



Ottone naturale non verniciato  
Natural brass not lacquered



Argento naturale non verniciato  
Natural silver not lacquered

Türdrücker per Paar  
in K

Nr.	Silber	Rot- brunne	Messing
1	2-10	1-80	1-40
2	2-60	2-20	1-70
3	3-00	2-50	2-00
4	3-50	3-00	2-40
5	1-90	1-70	1-50
6	2-50	2-10	1-60
14	2-50	2-20	1-90
15	3-00	2-50	2-20
16	3-50	2-80	2-40
17	3-80	3-20	2-40

Türdrücker per Paar  
in K

Nr.	Silber	Rot- brunne	Messing
4	12-40	10-60	8-00
8	8-20	7-00	5-40
16	12-00	10-30	7-80

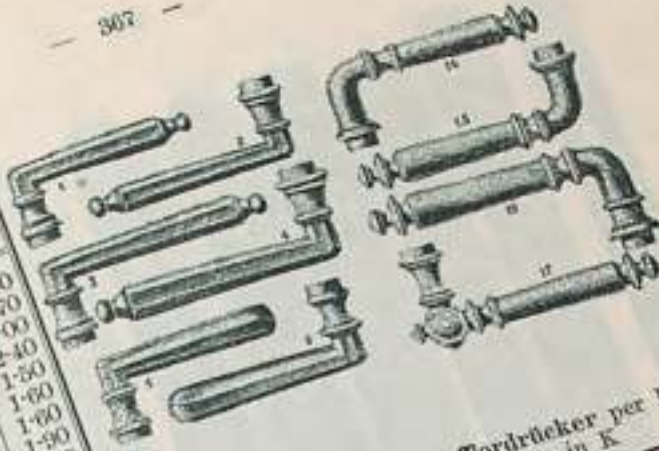

Türdrücker per Paar  
in K

Nr.	Silber	Rot- brunne	Messing
7	2-90	2-50	1-90
8	2-10	1-80	1-40
9	2-60	2-20	1-70
10	3-20	2-70	2-10
11	2-80	2-40	1-90
12	3-20	2-80	2-10
13	3-60	3-10	2-40
18	4-60	3-90	3-00
19	5-00	4-20	3-20
20 <sup>1)</sup>	4-20	3-50	2-70
20 <sup>2)</sup>	4-60	3-90	3-00
21	4-90	4-20	3-20
22 <sup>1)</sup>	3-90	3-30	2-50
22 <sup>2)</sup>	4-30	3-70	2-90
23	5-20	4-40	3-30

Türdrücker per Paar  
in K

Nr.	Silber	Rot- brunne	Messing
10	8-20	7-00	5-40
12	11-00	9-40	7-20
15	14-00	12-00	9-20

K 108)

ren  
hen  
teile, 076)

amen, 023)

arieren 080)

14)

iläge mit

omontieren

zuschlagen,

amettall.

welche sehr

nsehen gibt.

gelten nur für



# Ottocento

*La sala era ampia, la luce pioveva dall'alto e un'intera parete appariva ricoperta da una mostra di armi d'ogni foggia, gelida collezione di acciai su uno sfondo di stuoie e drappi.*

*Una piccola porta la metteva in comunicazione con lo studio. Dovevo solo allungare la mano e, fatto un passo, avrei raggiunto la magnifica maniglia di bronzo dell'uscio in ebano.*

*Joseph Conrad,  
La freccia d'oro (1919)*

*That room was very large, lighted from the top, and one wall of it was covered by trophies of arms of all sorts, a choice collection of cold steel disposed on a background of Indian mats and rugs.*

*Blunt used it as a dressing-room. It communicated by a small door with the studio.*

*I had only to extend my hand and make one step to reach the magnificent bronze handle of the ebony door.*

*Joseph Conrad,  
The arrow of Gold (1919)*

# Ottocento

*maniglie per porta su placca e rosetta*  
*door handles on plate and on rose*

materiale: ottone  
 material: brass

**KOT11 PB70**  
**KOT11 PB90**  
**KOT11 PBY85**

Ottone naturale non verniciato  
 Natural brass not lacquered

Bronzo non verniciato  
 Bronze not lacquered

Argento naturale non verniciato  
 Natural silver not lacquered

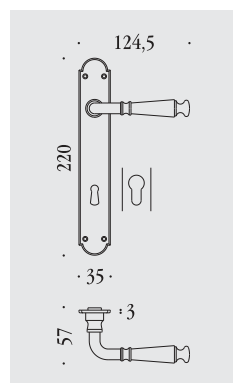

**KOT11 PBX70**  
**KOT11 PBX90**  
**KOT11 PBY85**

Ottone naturale non verniciato  
 Natural brass not lacquered

Bronzo non verniciato  
 Bronze not lacquered

Argento naturale non verniciato  
 Natural silver not lacquered

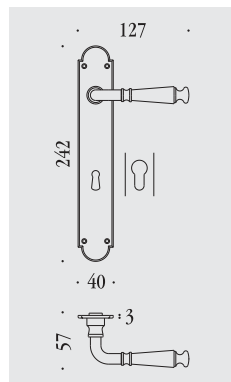

**KOT11 RB**  
**KOT11 RBY**

Ottone naturale non verniciato  
 Natural brass not lacquered

Bronzo non verniciato  
 Bronze not lacquered

Argento naturale non verniciato  
 Natural silver not lacquered

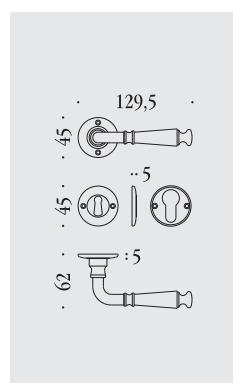

**KOT11 R**  
**KOT11 RY**

Ottone naturale non verniciato  
 Natural brass not lacquered

Bronzo non verniciato  
 Bronze not lacquered

Argento naturale non verniciato  
 Natural silver not lacquered

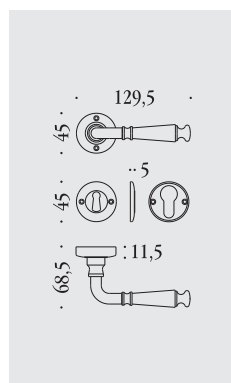

**KOT11 RBO**  
**KOT11 RBOY**

Ottone naturale non verniciato  
 Natural brass not lacquered

Bronzo non verniciato  
 Bronze not lacquered

Argento naturale non verniciato  
 Natural silver not lacquered

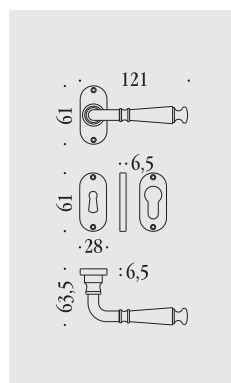

**KOT13 BP - KOT13 BY**  
**KOT19 BZG 6B**

Ottone naturale non verniciato  
 Natural brass not lacquered

Bronzo non verniciato  
 Bronze not lacquered

Argento naturale non verniciato  
 Natural silver not lacquered

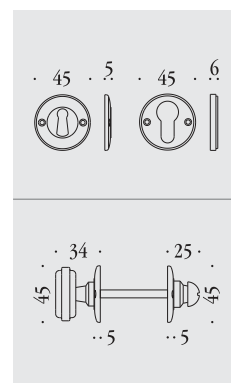

# Ottocento



Ottone naturale non verniciato  
Natural brass not lacquered



Bronzo non verniciato  
Bronze not lacquered



Argento naturale non verniciato  
Natural silver not lacquered

# Ottocento

*maniglie per finestra e per dreh-kipp  
window and dreh-kipp handles*

*materiale: ottone  
material: brass*

## **KOT12 B**

Ottone naturale non verniciato  
Natural brass not lacquered

Bronzo non verniciato  
Bronze not lacquered

Argento naturale non verniciato  
Natural silver not lacquered

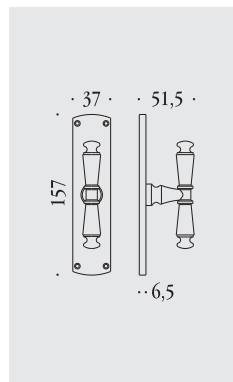

## **KOT12**

Ottone naturale non verniciato  
Natural brass not lacquered

Bronzo non verniciato  
Bronze not lacquered

Argento naturale non verniciato  
Natural silver not lacquered

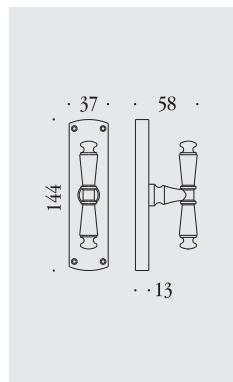

## **KOT12 CRDK**

Ottone naturale non verniciato  
Natural brass not lacquered

Bronzo non verniciato  
Bronze not lacquered

Argento naturale non verniciato  
Natural silver not lacquered

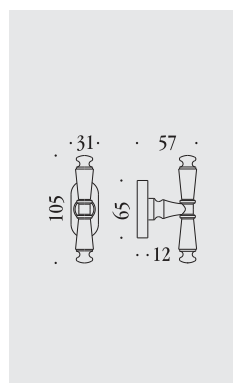

## **KOT12 DK/SM**

Ottone naturale non verniciato  
Natural brass not lacquered

Bronzo non verniciato  
Bronze not lacquered

Argento naturale non verniciato  
Natural silver not lacquered

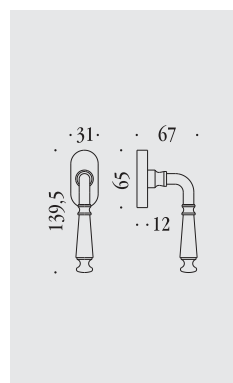



# Ottocento



Ottone naturale non verniciato  
Natural brass not lacquered



Ottone naturale non verniciato  
Natural brass not lacquered



Argento naturale non verniciato  
Natural silver not lacquered

OTTORINO RESPIGHI

# 4 LIRICHE

PER CANTO E PIANOFORTE



RICOR

# *Palatino*

*La porta girava quasi da sola;  
e la maniglia, liscia al tatto,  
aveva la dolcezza e come l'intesa  
di una mano nella sua mano.*

*Gustave Flaubert,  
L'educazione sentimentale (1869)*

*The door almost opened of its own  
accord; and the handle, smooth to  
the touch, gave him the sensation  
of friendly and, as it were,  
intelligent fingers clasping his.*

*Gustave Flaubert,  
Sentimental education (1869)*

# Palatino

*maniglie per porta su placca e rosetta*  
*door handles on plate and on rose*

*materiale: ottone*  
*material: brass*

**KPA11 PB70**  
**KPA11 PB90**  
**KAC11 PBY85**

Ottone naturale non verniciato  
 Natural brass not lacquered

Bronzo non verniciato  
 Bronze not lacquered

Nichel naturale non verniciato  
 Natural nickel not lacquered

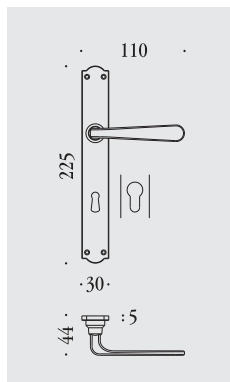

**KPA11 RB**  
**KPA11 RBY**

Ottone naturale non verniciato  
 Natural brass not lacquered

Bronzo non verniciato  
 Bronze not lacquered

Nichel naturale non verniciato  
 Natural nickel not lacquered

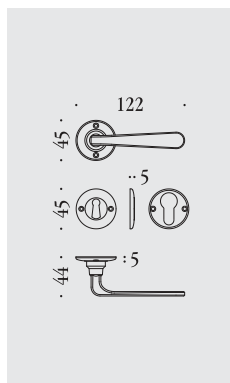

**KPA11 R**  
**KPA11 RY**

Ottone naturale non verniciato  
 Natural brass not lacquered

Bronzo non verniciato  
 Bronze not lacquered

Nichel naturale non verniciato  
 Natural nickel not lacquered

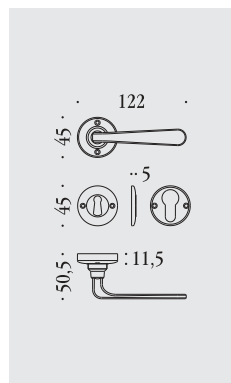

**KPA11 RBO**  
**KPA11 RBOY**

Ottone naturale non verniciato  
 Natural brass not lacquered

Bronzo non verniciato  
 Bronze not lacquered

Nichel naturale non verniciato  
 Natural nickel not lacquered

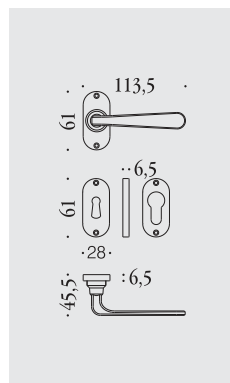

**KOT13 BP - KOT13 BY**  
**KOT19 BZG 6B**

Ottone naturale non verniciato  
 Natural brass not lacquered

Bronzo non verniciato  
 Bronze not lacquered

Nichel naturale non verniciato  
 Natural nickel not lacquered

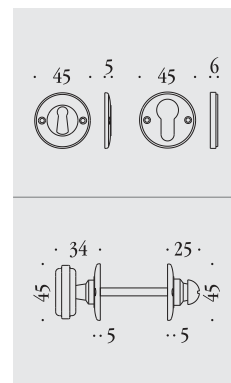

# Palatino



Ottone naturale non verniciato  
Natural brass not lacquered



Bronzo non verniciato  
Bronze not lacquered



Nichel naturale non verniciato  
Natural nickel not lacquered

# Palatino

maniglie per finestra e per dreh-kipp  
window and dreh-kipp handles

materiale: ottone  
material: brass

## KPA12 B

Ottone naturale non verniciato  
Natural brass not lacquered

Bronzo non verniciato  
Bronze not lacquered

Nichel naturale non verniciato  
Natural nickel not lacquered

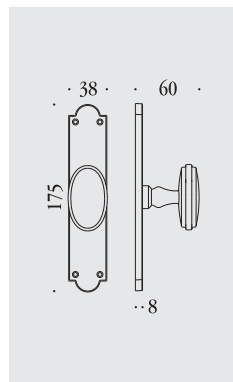

## KPA12

Ottone naturale non verniciato  
Natural brass not lacquered

Bronzo non verniciato  
Bronze not lacquered

Nichel naturale non verniciato  
Natural nickel not lacquered

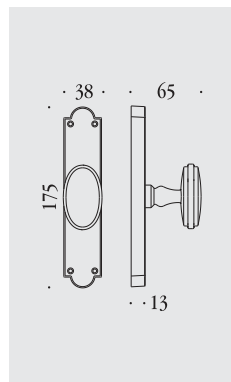

## KPA22 B

Ottone naturale non verniciato  
Natural brass not lacquered

Bronzo non verniciato  
Bronze not lacquered

Nichel naturale non verniciato  
Natural nickel not lacquered

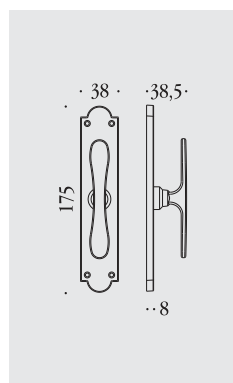

## KPA22

Ottone naturale non verniciato  
Natural brass not lacquered

Bronzo non verniciato  
Bronze not lacquered

Nichel naturale non verniciato  
Natural nickel not lacquered

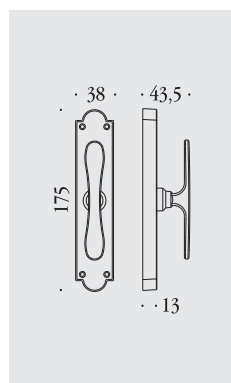

## KPA12 DK/SM

Ottone naturale non verniciato  
Natural brass not lacquered

Bronzo non verniciato  
Bronze not lacquered

Nichel naturale non verniciato  
Natural nickel not lacquered

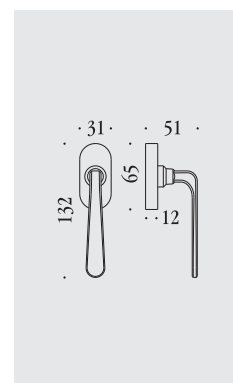

# *Palatino*



Ottone naturale non verniciato  
Natural brass not lacquered



Bronzo non verniciato  
Bronze not lacquered



Nichel naturale non verniciato  
Natural nickel not lacquered



NTAINE AU CO



VUE DU RHONE PR

WALTZES,  
Introducing "21 Rocks"  
201, Regent-street.

King (for the first  
"Lovers")

MUSICAL CHRISTMAS  
THE EXHIBITION MUSI  
including 12 extra  
Illustrations



# Roma

*Gadda si sistemò in una stanza  
insieme a un funzionario giovane  
di anni, ma un po' meno di  
aspetto, aggroitato e taciturno.  
Preferì che le due scrivanie fossero  
collocate una accanto all'altra  
proprio per non avere di fronte il  
corrugatissimo collega.  
Questo parlava poco, almeno nei  
primi giorni, ma si alzava  
continuamente fermandosi  
perplesso davanti alla porta con la  
mano sulla maniglia, poi apriva  
uno spiraglio con relativo cigolio e  
indugiava ancora pensoso mentre  
l'interiore incertezza gli si  
disegnava sulla fronte,  
moltiplicandone le rughe.*

*Giulio Cattaneo,  
Il gran lombardo (1911)*

*Gadda settled in a room with an  
official younger by years, but a bit  
less in appearance, frowning and  
silent.  
He preferred that the two desks  
were placed side by side in order  
not to have in front the corrugated  
colleague.  
This spoke little, at least in the early  
days, but he was used to get up  
continuously and stop perplexed in  
front of the door with his hand on  
the handle, then he was opening a  
glimmer with relative creaking and  
was delaying thoughtfully while the  
internal uncertainty was drawing  
himself on his forehead, multiplying  
the wrinkles.*

*Giulio Cattaneo,  
Il gran lombardo (1911)*

# Roma

*maniglie per porta su placca e rosetta*  
*door handles on plate and on rose*

*materiale: ottone*  
*material: brass*

**KSE21 PB70**  
**KSE21 PB90**  
**KSE21 PBY85**

Ottone naturale non verniciato  
 Natural brass not lacquered

Ottone lucido verniciato  
 Lacquered polished brass

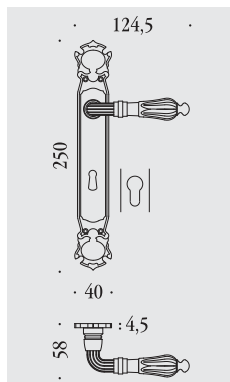

**KSE21 RB**  
**KSE21 RBY**

Ottone naturale non verniciato  
 Natural brass not lacquered

Ottone lucido verniciato  
 Lacquered polished brass

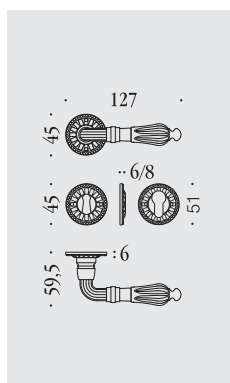

**KSE21 R**  
**KSE21 RY**

Ottone naturale non verniciato  
 Natural brass not lacquered

Ottone lucido verniciato  
 Lacquered polished brass

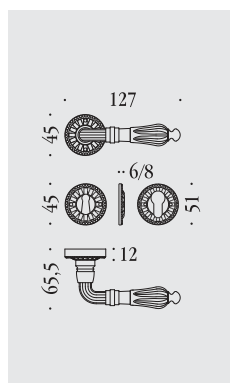

**KSE21 RBO**  
**KSE21 RBOY**

Ottone naturale non verniciato  
 Natural brass not lacquered

Ottone lucido verniciato  
 Lacquered polished brass

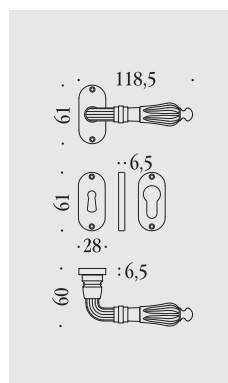

**KLU13 BP - KLU13 BY**  
**KSE19 BZG 6B**

Ottone naturale non verniciato  
 Natural brass not lacquered

Ottone lucido verniciato  
 Lacquered polished brass

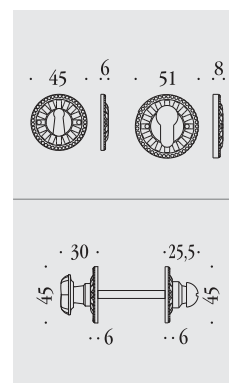

# Roma



Ottone naturale non verniciato  
Natural brass not lacquered

# Roma

*maniglie per finestra e per dreh-kipp  
window and dreh-kipp handles*

*materiale: ottone  
material: brass*

## **KSE22 B**

Ottone naturale non verniciato  
Natural brass not lacquered

Ottone lucido verniciato  
Lacquered polished brass

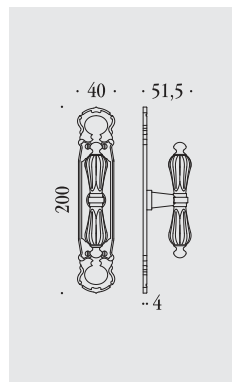

## **KSE22**

Ottone naturale non verniciato  
Natural brass not lacquered

Ottone lucido verniciato  
Lacquered polished brass

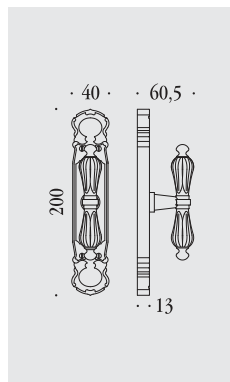

## **KSE22 CRDK**

Ottone naturale non verniciato  
Natural brass not lacquered

Ottone lucido verniciato  
Lacquered polished brass

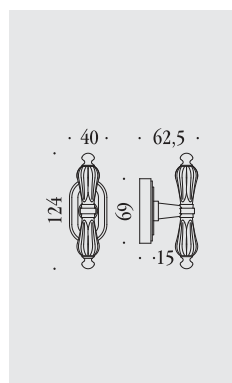

## **KSE22 DK/SM**

Ottone naturale non verniciato  
Natural brass not lacquered

Ottone lucido verniciato  
Lacquered polished brass

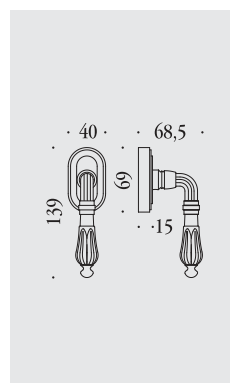



Ottone naturale non verniciato  
Natural brass not lacquered



Ottone naturale non verniciato  
Natural brass not lacquered



Ottone naturale non verniciato  
Natural brass not lacquered



CHARLES BUCHER

Picture. Copyrighted in the U.S.A.

CHRIS KEANE IN "R"  
Exhibited in 191

# Settecento

*Tra i particolari che mi erano sfuggiti a un primo sguardo notai che dalla maniglia della porta da cui ero entrato pendeva una rossa crinolina ...*

*Charles Dickens,  
The uncommercial Traveller (1861)*

*I had missed, at the first glance, some half a pound of bread in the otherwise empty safe, an old red ragged crinoline hanging on the handle of the door by which I had entered, and certain fragments of rusty iron scattered on the floor, ...*

*Charles Dickens,  
The uncommercial Traveller (1861)*

# Settecento

maniglie per porta su placca e rosetta  
door handles on plate and on rose

materiale: ottone  
material: brass

**KSE11 PB70**  
**KSE11 PB90**  
**KSE11 PBY85**

Ottone naturale non verniciato  
Natural brass not lacquered

Bronzo non verniciato  
Bronze not lacquered

Argento naturale non verniciato  
Natural silver not lacquered

**KSE11 PBX70**  
**KSE11 PBX90**  
**KSE11 PBXY85**

Ottone naturale non verniciato  
Natural brass not lacquered

Bronzo non verniciato  
Bronze not lacquered

Argento naturale non verniciato  
Natural silver not lacquered

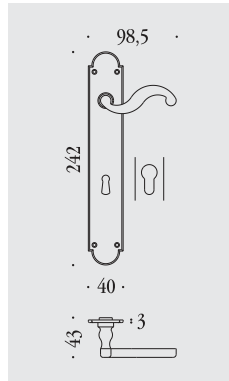
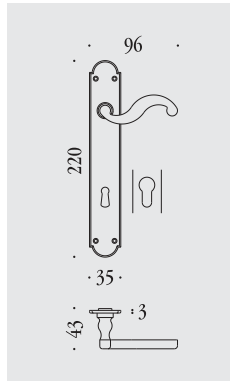

**KSE11 R**  
**KSE11 RY**

Ottone naturale non verniciato  
Natural brass not lacquered

Bronzo non verniciato  
Bronze not lacquered

Argento naturale non verniciato  
Natural silver not lacquered

**KSE11 RB**  
**KSE11 RBY**

Ottone naturale non verniciato  
Natural brass not lacquered

Bronzo non verniciato  
Bronze not lacquered

Argento naturale non verniciato  
Natural silver not lacquered

**KOT13 BP - KOT13 BY**  
**KOT19 BZG 6B**

Ottone naturale non verniciato  
Natural brass not lacquered

Bronzo non verniciato  
Bronze not lacquered

Argento naturale non verniciato  
Natural silver not lacquered

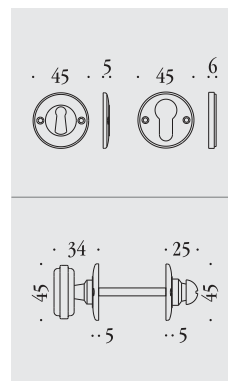
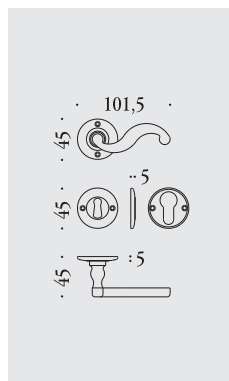
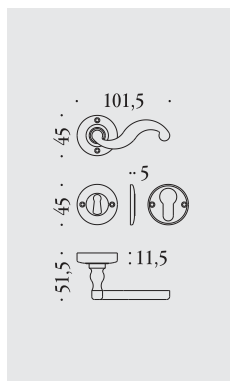



# Settecento



Ottone naturale non verniciato  
Natural brass not lacquered



Bronzo non verniciato  
Bronze not lacquered



Argento naturale non verniciato  
Natural silver not lacquered

# Settecento

*maniglie per finestra e per dreh-kipp*  
*window and dreh-kipp handles*

*materiale: ottone*  
*material: brass*

## **KSE12 B**

Ottone naturale non verniciato  
Natural brass not lacquered

Bronzo non verniciato  
Bronze not lacquered

Argento naturale non verniciato  
Natural silver not lacquered

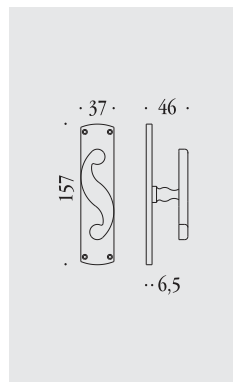

## **KSE12**

Ottone naturale non verniciato  
Natural brass not lacquered

Bronzo non verniciato  
Bronze not lacquered

Argento naturale non verniciato  
Natural silver not lacquered

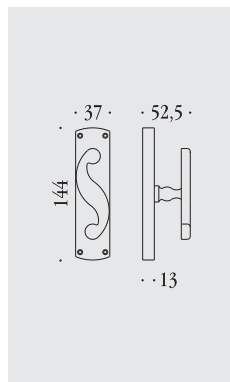

## **KSE12 DK/SM**

Ottone naturale non verniciato  
Natural brass not lacquered

Bronzo non verniciato  
Bronze not lacquered

Argento naturale non verniciato  
Natural silver not lacquered

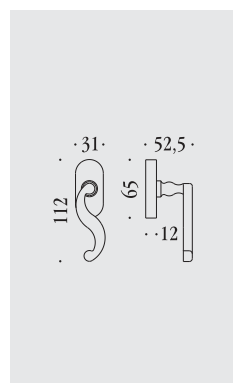

# Settecento



Ottone naturale non verniciato  
Natural brass not lacquered



Argento naturale non verniciato  
Natural silver not lacquered



*The famous Bridge of Rialto at Venice  
built with white Marble.*



# Venezia

*E Du Roy disse: "Sono io. E' inutile  
che cercate di farcela."  
Il passo leggero, un rumore di piedi  
scalzi, s'allontanò, poi tornò in  
capo a qualche secondo.  
Georges disse: "Se vi rifiutate  
d'aprire, sfonderemo la porta."  
Tenne stretta la maniglia d'ottone,  
e adagio si mise a spingere  
con una spalla.*

*Guy de Maupassant,  
Bel Ami (1885)*

*Du Roy said: "It is I. It is useless to  
seek to escape."  
The light steps, the tread of bare feet,  
was heard to withdraw, and then in  
a few seconds to return.  
George said: "If you won't open,  
we will break in the door".  
He grasped the handle, and pushed  
slowly with his shoulder.*

*Guy de Maupassant,  
Bel Ami (1885)*

# Venezia

*maniglie per porta su rosetta*  
*door handles on rose*

*materiale: ottone*  
*material: brass*



## ***KVE11 RB*** ***KVE11 RBY***

Ottone naturale non verniciato  
Natural brass not lacquered

Bronzo non verniciato  
Bronze not lacquered

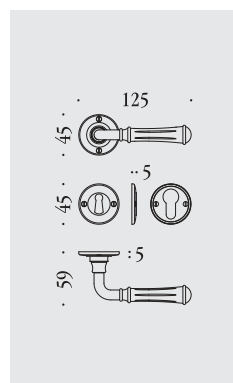

## ***KOT13 BP - KOT13 BY*** ***KOT19 BZG 6B***

Ottone naturale non verniciato  
Natural brass not lacquered

Bronzo non verniciato  
Bronze not lacquered

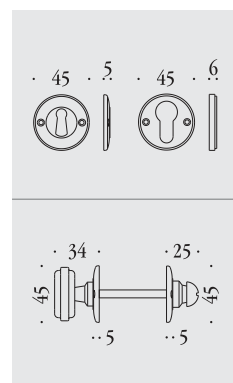



Ottone naturale non verniciato  
Natural brass not lacquered



Bronzo non verniciato  
Bronze not lacquered

# Venezia

*maniglie per finestra e per dreh-kipp  
window and dreh-kipp handles*

*materiale: ottone  
material: brass*

## **KVE12 B**

Ottone naturale non verniciato  
Natural brass not lacquered

Bronzo non verniciato  
Bronze not lacquered

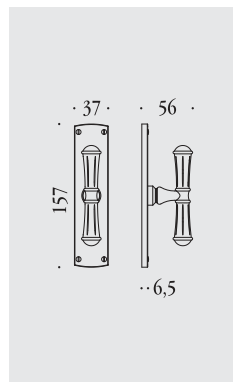

## **KVE12**

Ottone naturale non verniciato  
Natural brass not lacquered

Bronzo non verniciato  
Bronze not lacquered

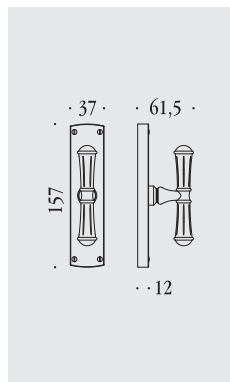

## **KVE12 CRDK**

Ottone naturale non verniciato  
Natural brass not lacquered

Bronzo non verniciato  
Bronze not lacquered

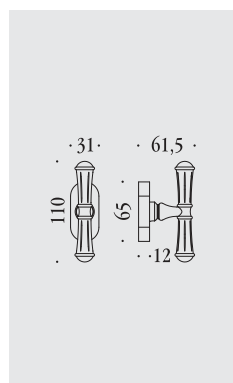

## **KVE12 DK/SM**

Ottone naturale non verniciato  
Natural brass not lacquered

Bronzo non verniciato  
Bronze not lacquered

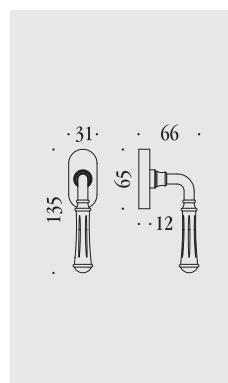





Bronzo non verniciato  
Bronze not lacquered



Bronzo non verniciato  
Bronze not lacquered



Ottone naturale non verniciato  
Natural brass not lacquered



*Nottolini*  
*Toilet roses*

# Antologhia)

nottolini  
toilet roses

materiale: ottone  
material: brass

## Accademia

KAC19 BZG 6B

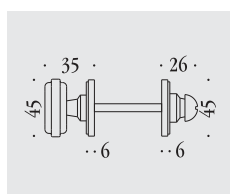

## Barocco

KBA19 BZG 6G

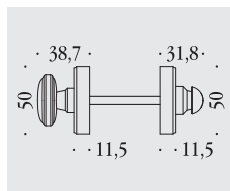

## Bellagio, Busiri

KBU19 BZG 6B

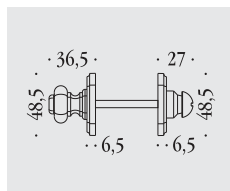

## Byblos

KBY19 BZG 6GB

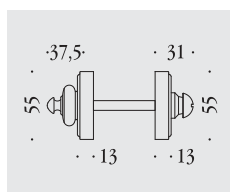

*Capri*

**KCR19 BZG 6B**

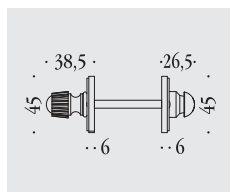

*Firenze, Lidia  
Ottocento, Palatino  
Settecento, Venezia*

**KOT19 BZG 6B**

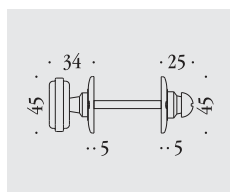

*Impero*

**KIM19 BZG 6B**

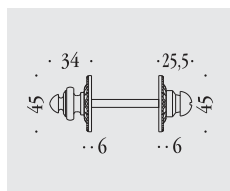

*Impero*

**KIM19 BZG 6GB**

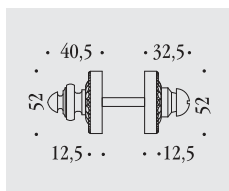

*Louis XVI*

**KLU19 BZG 6B**

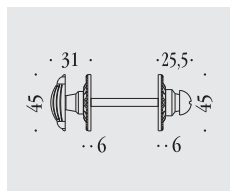

*Roma*

**KSE19 BZG 6B**

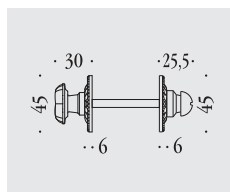



*Pomoli*  
*Door knobs*

# Busiri

*pomoli fissi*  
*fixed door knobs*

*materiale: ottone*  
*material: brass*

## **KBU25 FISSO**

Ottone naturale non verniciato  
Natural brass not lacquered

Bronzo non verniciato  
Bronze not lacquered

Argento naturale non verniciato  
Natural silver not lacquered

Cromo  
Chrome

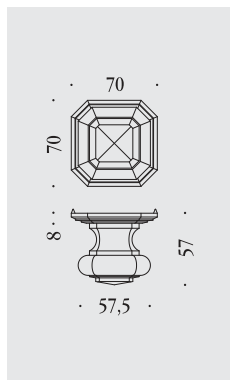

Ottone naturale non verniciato  
Natural brass not lacquered



## **KBU35 FISSO**

Ottone naturale non verniciato  
Natural brass not lacquered

Bronzo non verniciato  
Bronze not lacquered

Argento naturale non verniciato  
Natural silver not lacquered

Cromo  
Chrome

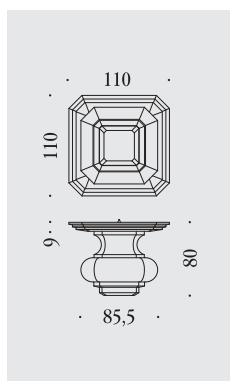

Ottone naturale non verniciato  
Natural brass not lacquered





# Byblos

*pomoli fissi*  
*fixed door knobs*

*materiale: ottone*  
*material: brass*

## **KBY15 FISSO**

Ottone lucido verniciato  
Lacquered polished brass

Bronzo satinato verniciato  
Lacquered satin bronze

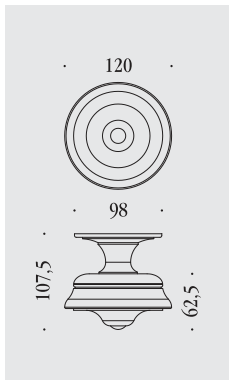

Ottone lucido verniciato  
Lacquered polished brass



## **KBY25 FISSO**

Ottone lucido verniciato  
Lacquered polished brass

Bronzo satinato verniciato  
Lacquered satin bronze

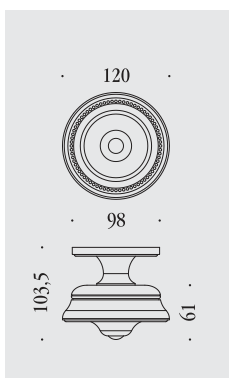

Bronzo satinato verniciato  
Lacquered satin bronze



# Doge

*pomoli fissi*  
*fixed door knobs*

*materiale: ottone*  
*material: brass*

## **KD015 FISSO**

Ottone naturale non verniciato  
Natural brass not lacquered

Bronzo non verniciato  
Bronze not lacquered

Argento naturale non verniciato  
Natural silver not lacquered

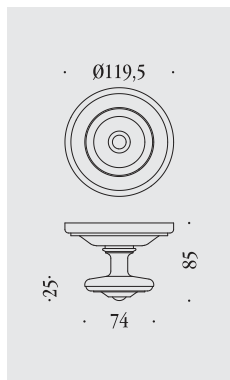

Ottone naturale non verniciato  
Natural brass not lacquered



# Accademia - Busiri

*pomoli girevoli*  
*turned door knobs*

*materiale: ottone*  
*material: brass*

*accademia*  
**KAC15 RB**  
**KAC15 RBY**

Ottone naturale non verniciato  
Natural brass not lacquered

Bronzo non verniciato  
Bronze not lacquered

Argento naturale non verniciato  
Natural silver not lacquered

*accademia*  
**KAC15 R**  
**KAC15 RY**

Ottone naturale non verniciato  
Natural brass not lacquered

Bronzo non verniciato  
Bronze not lacquered

Argento naturale non verniciato  
Natural silver not lacquered

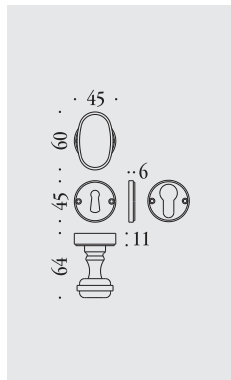
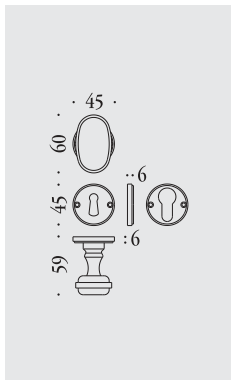

Ottone naturale non verniciato  
Natural brass not lacquered

*busiri*  
**KBU15 R**  
**KBU15 RY**

Ottone naturale non verniciato  
Natural brass not lacquered

Bronzo non verniciato  
Bronze not lacquered

Argento naturale non verniciato  
Natural silver not lacquered

Cromo  
Chrome

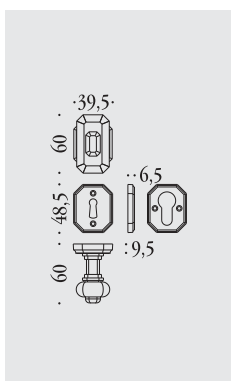

Ottone naturale non verniciato  
Natural brass not lacquered



# Louis XVI - Ottocento

## *pomoli girevoli* *turned door knobs*

*materiale: ottone*  
*material: brass*

*louis XVI*  
**KLU15 RB**  
**KLU15 RBY**

Ottone naturale non verniciato  
Natural brass not lacquered

Bronzo non verniciato  
Bronze not lacquered

Argento naturale non verniciato  
Natural silver not lacquered

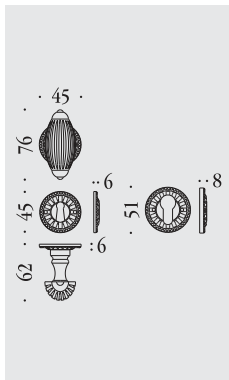

*louis XVI*  
**KLU15 R**  
**KLU15 RY**

Ottone naturale non verniciato  
Natural brass not lacquered

Bronzo non verniciato  
Bronze not lacquered

Argento naturale non verniciato  
Natural silver not lacquered

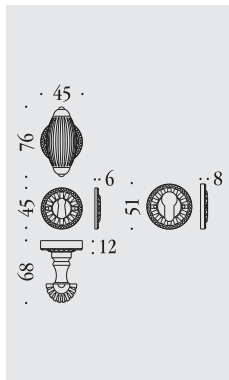

Ottone naturale non verniciato  
Natural brass not lacquered

*ottocento*  
**KOT15 RB**  
**KOT15 RBY**

Ottone naturale non verniciato  
Natural brass not lacquered

Bronzo non verniciato  
Bronze not lacquered

Argento naturale non verniciato  
Natural silver not lacquered

Nichel naturale non verniciato  
Natural nickel not lacquered

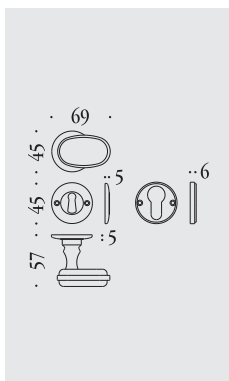

*ottocento*  
**KOT15 R**  
**KOT15 RY**

Ottone naturale non verniciato  
Natural brass not lacquered

Bronzo non verniciato  
Bronze not lacquered

Argento naturale non verniciato  
Natural silver not lacquered

Nichel naturale non verniciato  
Natural nickel not lacquered

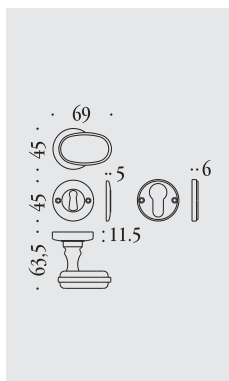

Ottone naturale non verniciato  
Natural brass not lacquered

# Roma - Versailles

*pomoli girevoli*  
*turned door knobs*

*materiale: ottone*  
*material: brass*

*roma*

**KSE15 RB**

**KSE15 RBY**

Ottone naturale non verniciato  
Natural brass not lacquered

Ottone lucido verniciato  
Lacquered polished brass

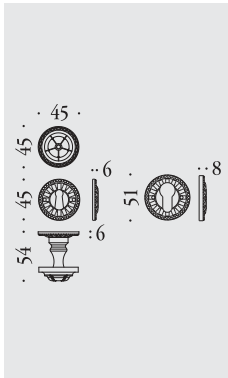

Ottone naturale non verniciato  
Natural brass not lacquered



*versailles*

**KLU25 RB**

**KLU25 RBY**

Ottone naturale non verniciato  
Natural brass not lacquered

Ottone lucido verniciato  
Lacquered polished brass

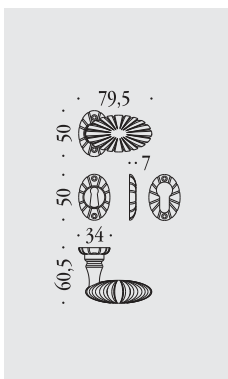

Ottone naturale non verniciato  
Natural brass not lacquered



# Accademia - Busiri

*pomoli per mobile*  
*furniture knobs*

*materiale: ottone*  
*material: brass*

## *accademia* **KAC119**

Ottone naturale non verniciato  
Natural brass not lacquered

Bronzo non verniciato  
Bronze not lacquered

Argento naturale non verniciato  
Natural silver not lacquered

Nichel naturale non verniciato  
Natural nickel not lacquered

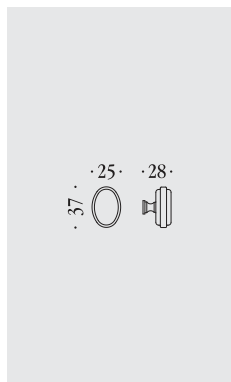

## *busiri* **KBU119/A**

Ottone naturale non verniciato  
Natural brass not lacquered

Bronzo non verniciato  
Bronze not lacquered

Argento naturale non verniciato  
Natural silver not lacquered

Cromo  
Chrome

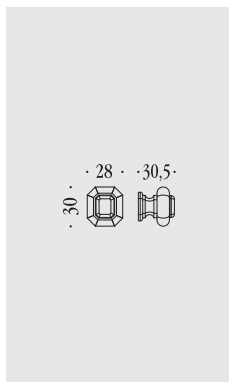

*accademia*  
Argento naturale non verniciato  
Natural silver not lacquered



*busiri*  
Argento naturale non verniciato  
Natural silver not lacquered

## *busiri* **KBU119/B**

Ottone naturale non verniciato  
Natural brass not lacquered

Bronzo non verniciato  
Bronze not lacquered

Argento naturale non verniciato  
Natural silver not lacquered

Cromo  
Chrome

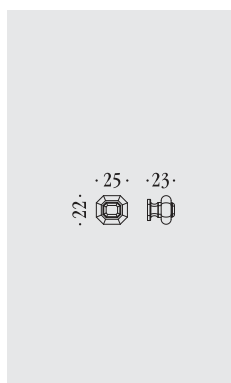

## *busiri* **KBU119/C**

Ottone naturale non verniciato  
Natural brass not lacquered

Bronzo non verniciato  
Bronze not lacquered

Argento naturale non verniciato  
Natural silver not lacquered

Cromo  
Chrome

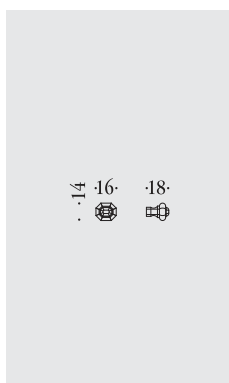

*busiri*  
Bronzo non verniciato  
Bronze not lacquered



*busiri*  
Ottone naturale non verniciato  
Natural brass not lacquered

# Capri - Impero - Louis XVI - Roma

*pomoli per mobile*  
*furniture knobs*

*materiale: ottone*  
*material: brass*

## *capri* **KCR119**

Ottone naturale non verniciato  
Natural brass not lacquered

Bronzo non verniciato  
Bronze not lacquered

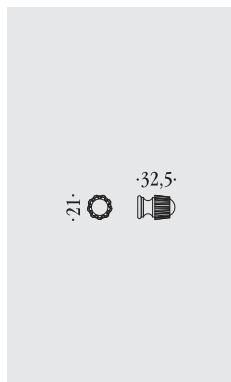

## *impero* **KIM119**

Ottone naturale non verniciato  
Natural brass not lacquered

Bronzo non verniciato  
Bronze not lacquered

Argento naturale non verniciato  
Natural silver not lacquered

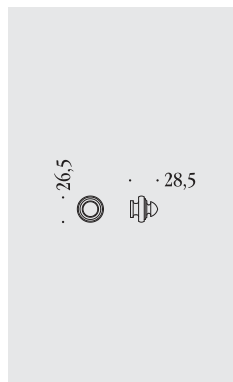

*capri*  
Bronzo non verniciato  
Bronze not lacquered



*impero*  
Ottone naturale non verniciato  
Natural brass not lacquered

## *louis XVI* **KLU119**

Ottone naturale non verniciato  
Natural brass not lacquered

Bronzo non verniciato  
Bronze not lacquered

Argento naturale non verniciato  
Natural silver not lacquered

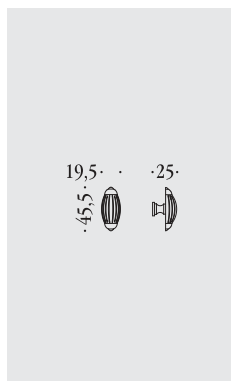

## *roma* **KSE119**

Ottone naturale non verniciato  
Natural brass not lacquered

Ottone lucido verniciato  
Lacquered polished brass



*louis XVI*  
Argento naturale non verniciato  
Natural silver not lacquered



*roma*  
Ottone lucido verniciato  
Lacquered polished brass



...SE IN THE DINING-ROOM OF OSBORNE HOUSE.



*Maniglioni e  
battiporta*  
*Pulls and door knockers*

# Barocco

## maniglioni pulls

materiale: ottone  
material: brass

### KBA16

Ottone naturale non verniciato  
Natural brass not lacquered

Bronzo non verniciato  
Bronze not lacquered

Argento naturale non verniciato  
Natural silver not lacquered

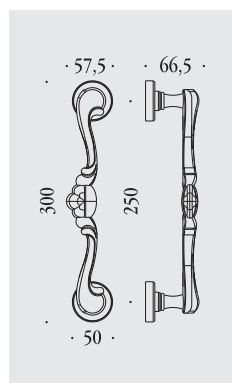

Argento naturale non verniciato  
Natural silver not lacquered



## **KBU16**

Ottone naturale non verniciato  
Natural brass not lacquered

Bronzo non verniciato  
Bronze not lacquered

Argento naturale non verniciato  
Natural silver not lacquered

Cromo  
Chrome

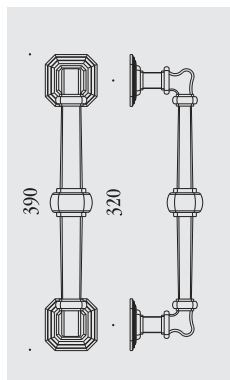

Ottone naturale non verniciato  
Natural brass not lacquered



# Busiri

## maniglioni pulls

materiale: ottone  
material: brass

### **KBU26 NP**

Ottone naturale non verniciato  
Natural brass not lacquered

Bronzo non verniciato  
Bronze not lacquered

Argento naturale non verniciato  
Natural silver not lacquered

Cromo  
Chrome

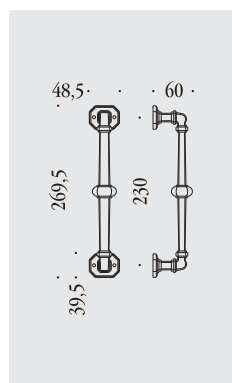

Ottone naturale non verniciato  
Natural brass not lacquered

### **KBU26 PS**

Ottone naturale non verniciato  
Natural brass not lacquered

Bronzo non verniciato  
Bronze not lacquered

Argento naturale non verniciato  
Natural silver not lacquered

Cromo  
Chrome

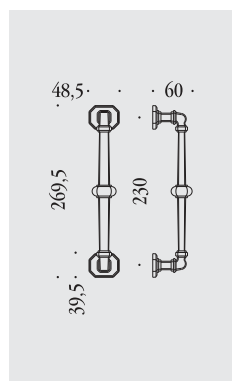

Bronzo non verniciato  
Bronze not lacquered



# Byblos

maniglioni  
pulls

materiale: ottone  
material: brass

## KBY16

Ottone lucido verniciato  
Lacquered polished brass

Bronzo satinato verniciato  
Lacquered satin bronze

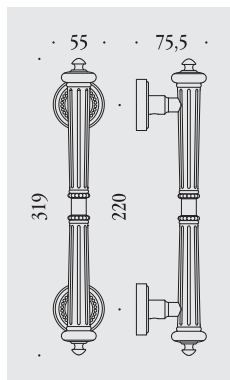

Bronzo satinato verniciato  
Lacquered satin bronze



## KBY16 NP

Ottone lucido verniciato  
Lacquered polished brass

Bronzo satinato verniciato  
Lacquered satin bronze

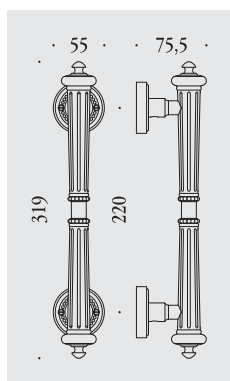

# Byblos

*maniglioni  
pulls*

*materiale: ottone  
material: brass*

## **KBY26**

Ottone lucido verniciato  
Lacquered polished brass

Bronzo satinato verniciato  
Lacquered satin bronze

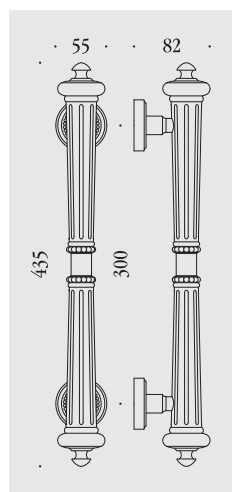

Ottone lucido verniciato  
Lacquered polished brass

## **KBY26 NP**

Ottone lucido verniciato  
Lacquered polished brass

Bronzo satinato verniciato  
Lacquered satin bronze

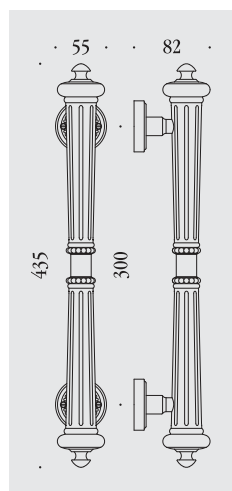

# Capri

*maniglioni  
pulls*

*materiale: ottone  
material: brass*

## KCR16

Ottone naturale non verniciato  
Natural brass not lacquered

Bronzo non verniciato  
Bronze not lacquered

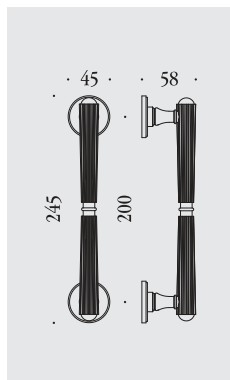

Ottone naturale non verniciato  
Natural brass not lacquered

## KCR26

Ottone naturale non verniciato  
Natural brass not lacquered

Bronzo non verniciato  
Bronze not lacquered

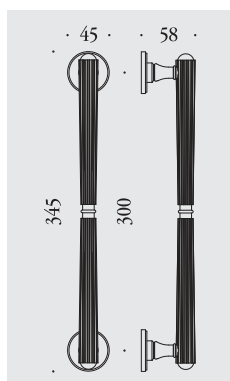

Bronzo non verniciato  
Bronze not lacquered



# Impero

*maniglioni  
pulls*

*materiale: ottone  
material: brass*

## **KIM16**

Ottone naturale non verniciato  
Natural brass not lacquered

Bronzo non verniciato  
Bronze not lacquered

Argento naturale non verniciato  
Natural silver not lacquered

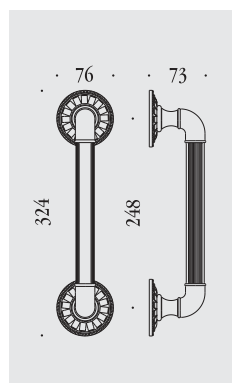

Ottone naturale non verniciato  
Natural brass not lacquered





# Impero

*maniglioni  
pulls*

*materiale: ottone  
material: brass*

## **KIM26**

Ottone naturale non verniciato  
Natural brass not lacquered

Bronzo non verniciato  
Bronze not lacquered

Argento naturale non verniciato  
Natural silver not lacquered

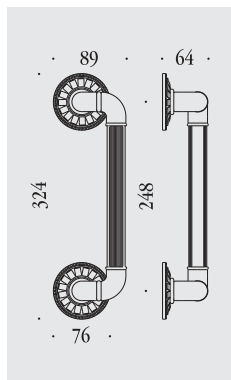

Ottone naturale non verniciato  
Natural brass not lacquered



# Louis XVI

## maniglioni pulls

materiale: ottone  
material: brass

### **KLU16 NP**

Ottone naturale non verniciato  
Natural brass not lacquered

Bronzo non verniciato  
Bronze not lacquered

Argento naturale non verniciato  
Natural silver not lacquered

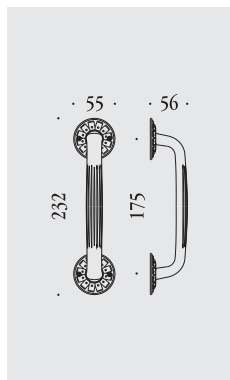

Ottone naturale non verniciato  
Natural brass not lacquered

### **KLU16 PS**

Ottone naturale non verniciato  
Natural brass not lacquered

Bronzo non verniciato  
Bronze not lacquered

Argento naturale non verniciato  
Natural silver not lacquered

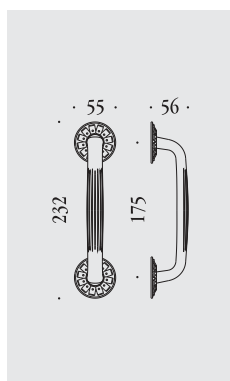

# Louis XVI

*maniglioni  
pulls*

*materiale: ottone  
material: brass*

## **KLU26 NP**

Ottone naturale non verniciato  
Natural brass not lacquered

Bronzo non verniciato  
Bronze not lacquered

Argento naturale non verniciato  
Natural silver not lacquered

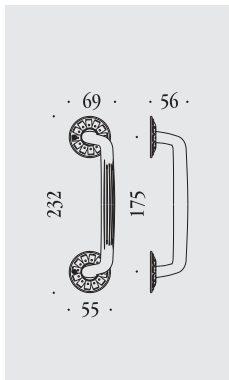

Ottone naturale non verniciato  
Natural brass not lacquered



## **KLU26 PS**

Ottone naturale non verniciato  
Natural brass not lacquered

Bronzo non verniciato  
Bronze not lacquered

Argento naturale non verniciato  
Natural silver not lacquered

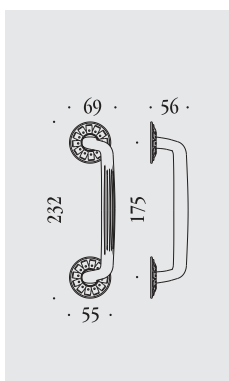

# Ottocento

## maniglioni pulls

materiale: ottone  
material: brass

### KOT16

Ottone naturale non verniciato  
Natural brass not lacquered

Bronzo non verniciato  
Bronze not lacquered

Argento naturale non verniciato  
Natural silver not lacquered

Nichel naturale non verniciato  
Natural nickel not lacquered

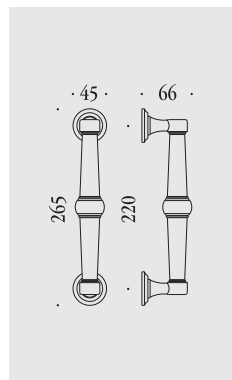

Ottone naturale non verniciato  
Natural brass not lacquered

### KOT26

Ottone naturale non verniciato  
Natural brass not lacquered

Bronzo non verniciato  
Bronze not lacquered

Argento naturale non verniciato  
Natural silver not lacquered

Nichel naturale non verniciato  
Natural nickel not lacquered

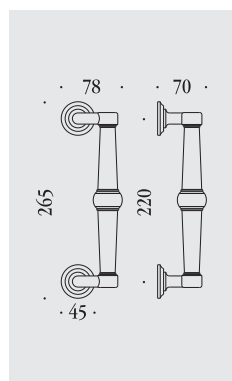

Ottone naturale non verniciato  
Natural brass not lacquered



# Venezia

*maniglioni  
pulls*

*materiale: ottone  
material: brass*

## **KVE16**

Ottone naturale non verniciato  
Natural brass not lacquered

Bronzo non verniciato  
Bronze not lacquered

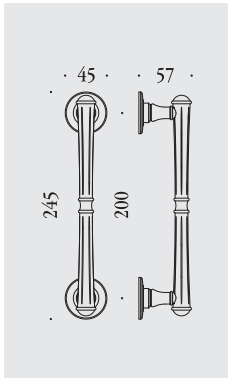

Bronzo non verniciato  
Bronze not lacquered

## **KVE26**

Ottone naturale non verniciato  
Natural brass not lacquered

Bronzo non verniciato  
Bronze not lacquered

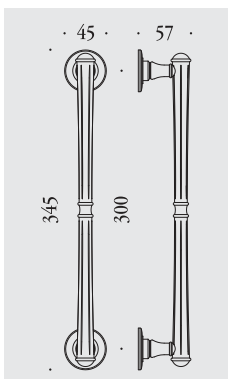

Ottone naturale non verniciato  
Natural brass not lacquered



# Vitto

## maniglioni pulls

materiale: ottone  
material: brass

### KOT36

Ottone naturale non verniciato  
Natural brass not lacquered

Bronzo non verniciato  
Bronze not lacquered

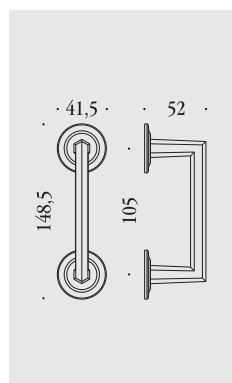

Bronzo non verniciato  
Bronze not lacquered



# Busiri

maniglioni per alzante scorrevole  
pull-up handles for sliding door

materiale: ottone  
material: brass

## KBU113

Ottone naturale non verniciato  
Natural brass not lacquered

Bronzo non verniciato  
Bronze not lacquered

Argento naturale non verniciato  
Natural silver not lacquered

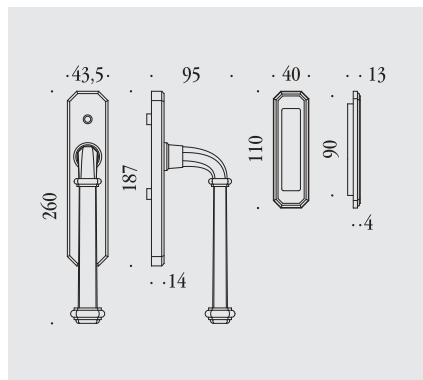

Ottone naturale non verniciato  
Natural brass not lacquered



# Impero

*maniglioni per alzante scorrevole*  
*pull-up handles for sliding door*

*materiale: ottone*  
*material: brass*

## **KIM113**

Ottone naturale non verniciato  
Natural brass not lacquered

Bronzo non verniciato  
Bronze not lacquered

Argento naturale non verniciato  
Natural silver not lacquered

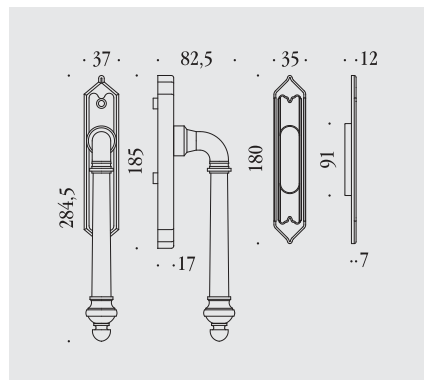

Ottone naturale non verniciato  
Natural brass not lacquered





# Louis XVI

*maniglioni per alzante scorrevole*  
*pull-up handles for sliding door*

*materiale: ottone*  
*material: brass*

## **KLU113**

Ottone naturale non verniciato  
Natural brass not lacquered

Bronzo non verniciato  
Bronze not lacquered

Argento naturale non verniciato  
Natural silver not lacquered

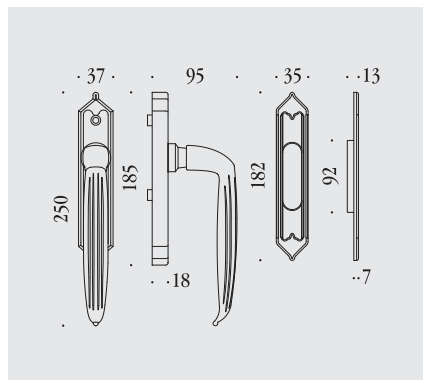

Ottone naturale non verniciato  
Natural brass not lacquered



# Ottocento

## *battiporta* *door knockers*

*materiale: ottone*  
*material: brass*

### **KOT115**

Ottone naturale non verniciato  
Natural brass not lacquered

Bronzo non verniciato  
Bronze not lacquered

Argento naturale non verniciato  
Natural silver not lacquered

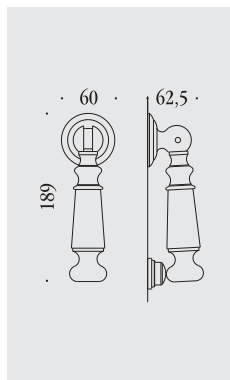

Ottone naturale non verniciato  
Natural brass not lacquered



# Ottocento

*battiporta*  
*door knockers*

*materiale: ottone*  
*material: brass*

## **KOT215**

Ottone naturale non verniciato  
Natural brass not lacquered

Bronzo non verniciato  
Bronze not lacquered

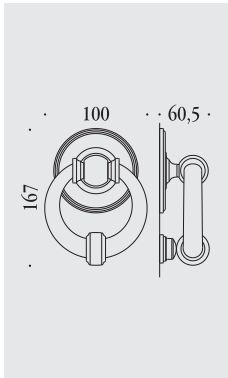

Bronzo non verniciato  
Bronze not lacquered





*Maniglie  
incasso*  
*Flush handles*

# Busiri

*maniglie incasso*  
*flush handles*

*materiale: ottone*  
*material: brass*

## **KBU111**

Ottone naturale non verniciato  
Natural brass not lacquered

Bronzo non verniciato  
Bronze not lacquered

Argento naturale non verniciato  
Natural silver not lacquered

Cromo  
Chrome

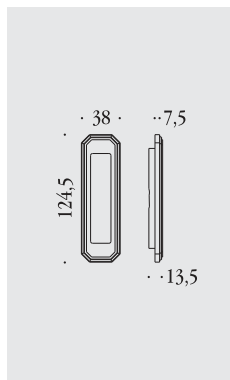

Ottone naturale non verniciato  
Natural brass not lacquered



## **KBU111 CF**

Ottone naturale non verniciato  
Natural brass not lacquered

Bronzo non verniciato  
Bronze not lacquered

Argento naturale non verniciato  
Natural silver not lacquered

Cromo  
Chrome

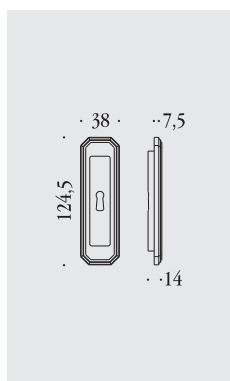

Bronzo non verniciato  
Bronze not lacquered



# Louis XVI

*maniglie incasso  
flush handles*

*materiale: ottone  
material: brass*

## **KLU111**

Ottone naturale non verniciato  
Natural brass not lacquered

Bronzo non verniciato  
Bronze not lacquered

Argento naturale non verniciato  
Natural silver not lacquered

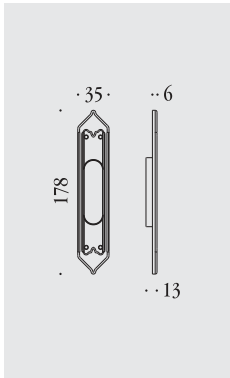

Bronzo non verniciato  
Bronze not lacquered

## **KLU111 CF**

Ottone naturale non verniciato  
Natural brass not lacquered

Bronzo non verniciato  
Bronze not lacquered

Argento naturale non verniciato  
Natural silver not lacquered

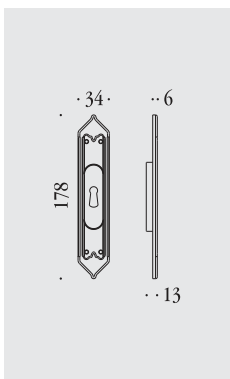

Argento naturale non verniciato  
Natural silver not lacquered



# Ottocento

## *maniglie incasso* *flush handles*

*materiale: ottone*  
*material: brass*

### **KOT111**

Ottone naturale non verniciato  
Natural brass not lacquered

Bronzo non verniciato  
Bronze not lacquered

Argento naturale non verniciato  
Natural silver not lacquered

Nichel naturale non verniciato  
Natural nickel not lacquered

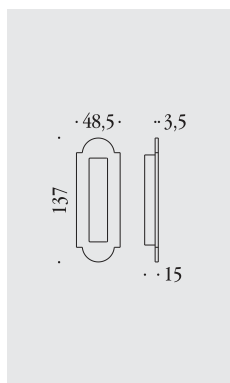

Bronzo non verniciato  
Bronze not lacquered





**KOT111 CF**

Ottone naturale non verniciato  
Natural brass not lacquered

Bronzo non verniciato  
Bronze not lacquered

Argento naturale non verniciato  
Natural silver not lacquered

Nichel naturale non verniciato  
Natural nickel not lacquered

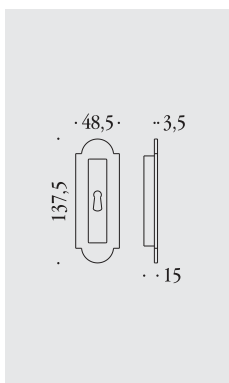

Argento naturale non verniciato  
Natural silver not lacquered





*Complementi*  
*Complements*

# Ottocento

*cremonese per aste esterne*  
*window handles for external rods*

*materiale: ottone*  
*material: brass*

## **KOT22 AV**

Ottone naturale non verniciato  
Natural brass not lacquered

Bronzo non verniciato  
Bronze not lacquered

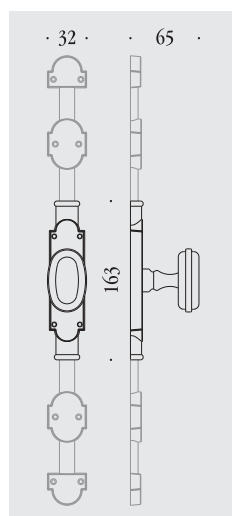

Ottone naturale non verniciato  
Natural brass not lacquered



## **KOT22 A0160**

Ottone naturale non verniciato  
Natural brass not lacquered

Bronzo non verniciato  
Bronze not lacquered

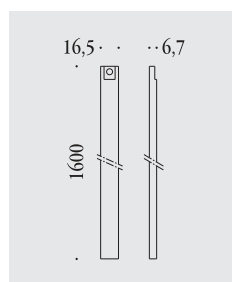

## **KOT22 A0250**

Ottone naturale non verniciato  
Natural brass not lacquered

Bronzo non verniciato  
Bronze not lacquered

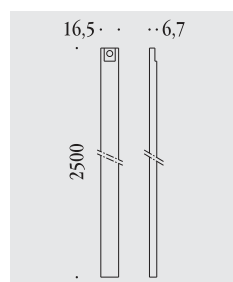

Ottone naturale non verniciato  
Natural brass not lacquered



# Ottocento

*cremonese per aste esterne*  
*window handles for external rods*

*materiale: ottone*  
*material: brass*

## **KOT22 PS**

Ottone naturale non verniciato  
Natural brass not lacquered

Bronzo non verniciato  
Bronze not lacquered

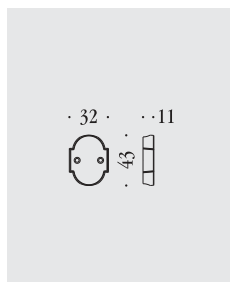

Ottone naturale non verniciato  
Natural brass not lacquered



## **KOT22 TO**

Ottone naturale non verniciato  
Natural brass not lacquered

Bronzo non verniciato  
Bronze not lacquered

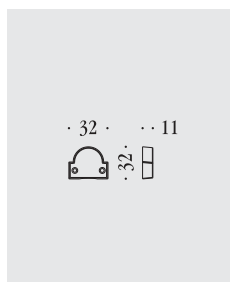

Ottone naturale non verniciato  
Natural brass not lacquered



# Busiri - Impero

## chiavi keys

materiale: ottone  
material: brass

### **KBU14**

Ottone naturale non verniciato  
Natural brass not lacquered

Bronzo non verniciato  
Bronze not lacquered

Argento naturale non verniciato  
Natural silver not lacquered

Cromo  
Chrome

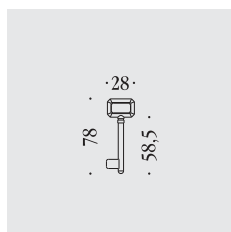

Ottone naturale non verniciato  
Natural brass not lacquered



### **KIM14**

Ottone naturale non verniciato  
Natural brass not lacquered

Bronzo non verniciato  
Bronze not lacquered

Argento naturale non verniciato  
Natural silver not lacquered

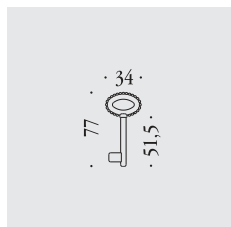

### **KIM24**

Ottone naturale non verniciato  
Natural brass not lacquered

Bronzo non verniciato  
Bronze not lacquered

Argento naturale non verniciato  
Natural silver not lacquered

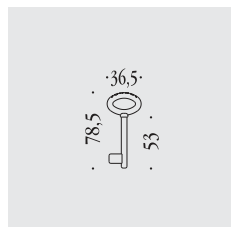

Ottone naturale  
Natural brass  
not lacquered



# Louis XVI - Settecento

*chiavi*  
*keys*

*materiale: ottone*  
*material: brass*

## **KLU14**

Ottone naturale non verniciato  
Natural brass not lacquered

Bronzo non verniciato  
Bronze not lacquered

Argento naturale non verniciato  
Natural silver not lacquered

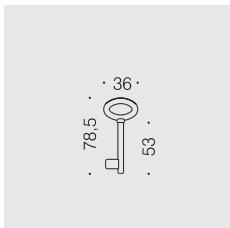

Ottone naturale non verniciato  
Natural brass not lacquered



## **KSE14**

Ottone naturale non verniciato  
Natural brass not lacquered

Bronzo non verniciato  
Bronze not lacquered

Argento naturale non verniciato  
Natural silver not lacquered

Nichel naturale non verniciato  
Natural nickel not lacquered

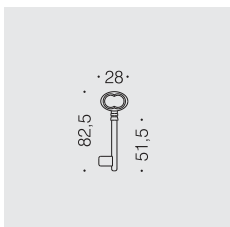

Ottone naturale non verniciato  
Natural brass not lacquered



# Ottocento

## campanelli e targhetta door bells and name plate

materiale: ottone  
material: brass

### KOT418

Ottone naturale non verniciato  
Natural brass not lacquered

Bronzo non verniciato  
Bronze not lacquered

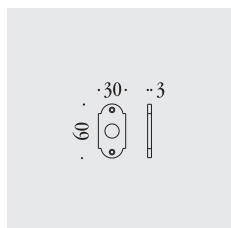

Ottone naturale non verniciato  
Natural brass not lacquered



### KOT318

Ottone naturale non verniciato  
Natural brass not lacquered

Bronzo non verniciato  
Bronze not lacquered

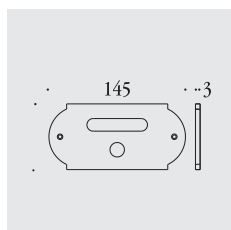

Ottone naturale non verniciato  
Natural brass not lacquered



### KOT118

Ottone naturale non verniciato  
Natural brass not lacquered

Bronzo non verniciato  
Bronze not lacquered

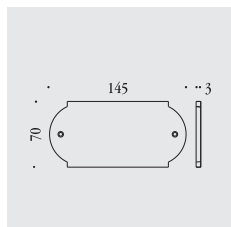

Ottone naturale non verniciato  
Natural brass not lacquered





# Ottocento

*buca per lettere*  
*letter plate*

*materiale: ottone*  
*material: brass*

## **KOT218**

Ottone naturale non verniciato  
Natural brass not lacquered

Bronzo non verniciato  
Bronze not lacquered

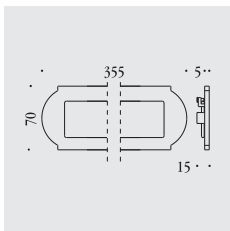

Ottone naturale non verniciato  
Natural brass not lacquered



# Louis XVI

## coprinterruttori switch plate

materiale: ottone  
material: brass

### ***KLUI8/A L.L.*** ***KLUI8/A M.TT*** ***KLUI8/A V.I.***

Ottone naturale non verniciato  
Natural brass not lacquered

Bronzo non verniciato  
Bronze not lacquered

Argento naturale non verniciato  
Natural silver not lacquered

Cromo  
Chrome

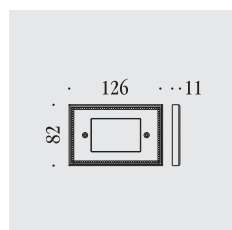

Ottone naturale non verniciato  
Natural brass not lacquered



### ***KLUI8/A MAGIC***

Ottone naturale non verniciato  
Natural brass not lacquered

Bronzo non verniciato  
Bronze not lacquered

Argento naturale non verniciato  
Natural silver not lacquered

Cromo  
Chrome

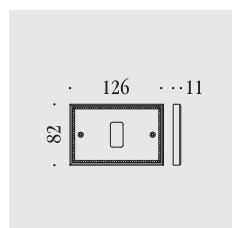

### ***KLUI8/B MAGIC***

Ottone naturale non verniciato  
Natural brass not lacquered

Bronzo non verniciato  
Bronze not lacquered

Argento naturale non verniciato  
Natural silver not lacquered

Cromo  
Chrome

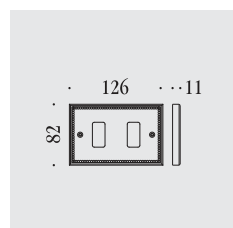

### ***KLUI8/C MAGIC***

Ottone naturale non verniciato  
Natural brass not lacquered

Bronzo non verniciato  
Bronze not lacquered

Argento naturale non verniciato  
Natural silver not lacquered

Cromo  
Chrome

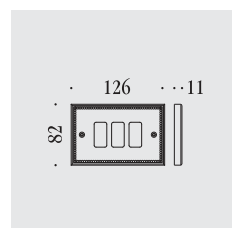

# Ottocento

*coprinterruttori  
switch plate*

*materiale: ottone  
material: brass*

**KOT18/A L.L.**  
**KOT18/A M.TT**  
**KOT18/A V.I.**

Ottone naturale non verniciato  
Natural brass not lacquered

Bronzo non verniciato  
Bronze not lacquered

Argento naturale non verniciato  
Natural silver not lacquered

Cromo  
Chrome

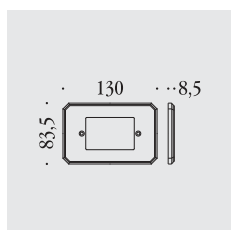

Bronzo non verniciato  
Bronze not lacquered



**KOT18/A MAGIC**

Ottone naturale non verniciato  
Natural brass not lacquered

Bronzo non verniciato  
Bronze not lacquered

Argento naturale non verniciato  
Natural silver not lacquered

Cromo  
Chrome

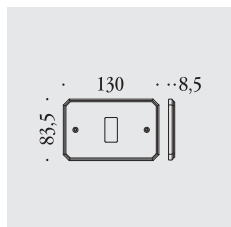

**KOT18/B MAGIC**

Ottone naturale non verniciato  
Natural brass not lacquered

Bronzo non verniciato  
Bronze not lacquered

Argento naturale non verniciato  
Natural silver not lacquered

Cromo  
Chrome

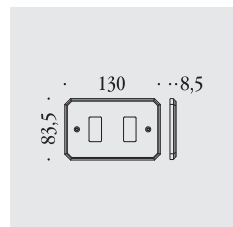

**KOT18/C MAGIC**

Ottone naturale non verniciato  
Natural brass not lacquered

Bronzo non verniciato  
Bronze not lacquered

Argento naturale non verniciato  
Natural silver not lacquered

Cromo  
Chrome

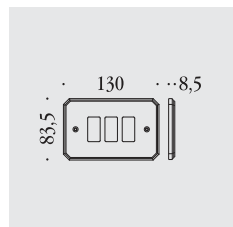

# Byblos

*fermaporta*  
*door stoppers*

*materiale: ottone*  
*material: brass*

## **KBY112**

Ottone lucido verniciato  
Lacquered polished brass

Bronzo satinato verniciato  
Lacquered satin bronze

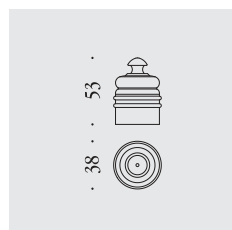

Ottone lucido verniciato  
Lacquered polished brass



# Universali

*fermaporta  
door stoppers*

*materiale: ottone  
material: brass*

## **KUN112**

Ottone naturale non verniciato  
Natural brass not lacquered

Bronzo non verniciato  
Bronze not lacquered

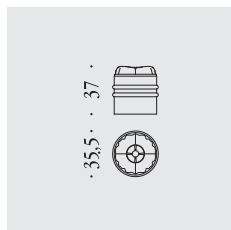

Ottone naturale non verniciato  
Natural brass not lacquered





**Lo sviluppo è sostenibile se soddisfa i bisogni delle generazioni presenti senza compromettere le possibilità per le generazioni future di soddisfare i propri bisogni.**

*Sustainable development is development that meets the needs of the present without compromising the ability of future generations to meet their own needs.*

*(Brundtland Report, United Nations, 1987)*

**E' tempo di Green Made.**

Green Made significa pensare, progettare e produrre in armonia con l'ambiente.

**It's Green Made time.**

Green made means thinking, developing and manufacturing in harmony with our environment.

follow us on



[www.colombodesign.it](http://www.colombodesign.it)

Concept and graphic design  
**Colombo Design**

Printed in Italy  
**03/15**

Colombo Design si riserva di apportare ai propri prodotti ogni modifica estetica e tecnica che a suo insindacabile giudizio ritenga necessaria.

Il presente catalogo è tutelato dalla legge sui diritti di autore di esso è quindi proibita ogni riproduzione, totale o anche parziale.

Il listino prezzi può avere frequenze di aggiornamento superiori al catalogo generale, costituisce quindi lo strumento di consultazione più aggiornato.

Le textures ed i colori dei materiali e delle finiture hanno valore indicativo in quanto soggetti alle tolleranze dei processi di stampa.

Le misure indicate sono espresse, se non specificato diversamente, in millimetri.

Colombo Design reserves the right to modify parts of its collection range whenever necessary without previous notice.

This catalogue is protected by the Italian copyright laws. No part of this catalogue may be reproduced in any form or by any means

The price-list has a printing frequency higher than the general catalogue, therefore it is the most up-dated consulting tool.

The textures and colours of materials and finishes are not binding as they depend on printing colour tolerances.

All measures mentioned herein are stated in millimeters, if not differently specified.